

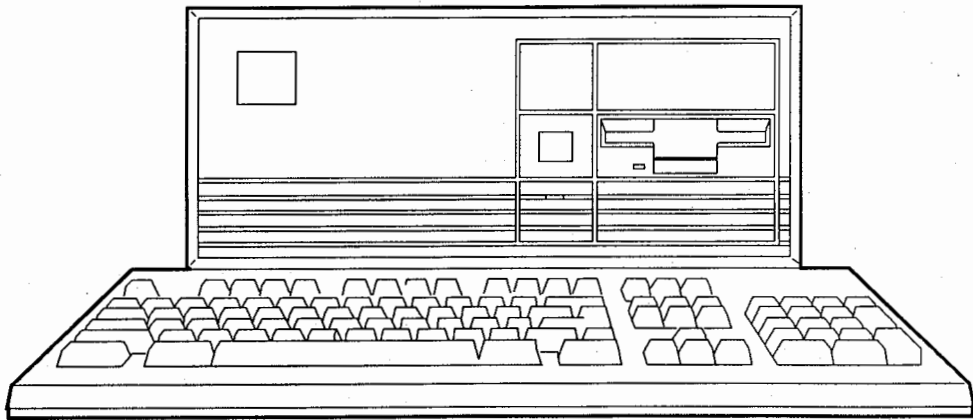

**ZENITH**  
data systems

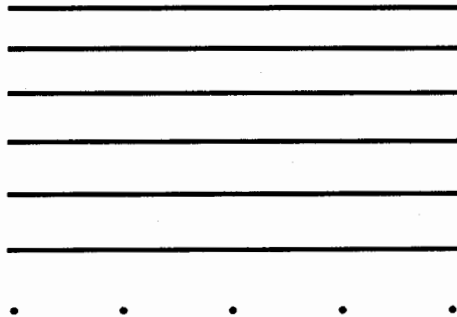

Groupe Bull



**Z-386SX/20**

**Owner's Manual**

595-5036

**Copyright © 1991 by Zenith Data Systems Corporation.**

This material may be reproduced by or for the U.S. Government pursuant to the copyright license under the clause at DFARS 252.227-7013 (Oct. 1988); or, if provided under a contract or subcontract with NASA or a civilian agency of the Government, this material may be reproduced in accordance with the provisions of the contract or subcontract with Zenith Data Systems Corporation, Hilltop Road, St. Joseph, Michigan 49085.  
**All other rights reserved.**

**Trademarks**

PS/2 is a trademark of IBM.

TIGA is a trademark of Texas Instruments.

Microsoft Windows is a trademark of Microsoft Corporation.

Hercules is a registered trademark of Hercules Computer Technology.

Printed in the United States of America.

## REGULATORY INFORMATION

**Note:** This equipment has been tested and found to comply with the limits for a Class B digital device, pursuant to Part 15 of FCC Rules. These limits are designed to provide reasonable protection against harmful interference in a residential installation.

This equipment generates, uses, and can radiate radio frequency energy. If not installed and used according to this manual, the equipment may cause harmful interference with radio and television communications. However, there is no guarantee that interference will not occur in any particular installation.

**Note:** To meet Class B emission limits, the user must observe the following requirements:

1. Use only shielded I/O cables to connect this digital device with any peripheral (such as a printer, modem, monitor, etc.).
2. The manufacturer ships this digital device with a shielded line (power) cord. If you replace the line cord, use only a shielded line cord.
3. The user is cautioned that changes or modifications not expressly approved by the party responsible for compliance could void the user's authority to operate the equipment.

If this equipment does cause interference with radio or television reception, which you can determine by turning the equipment off and on, try to correct the interference by using one or more of the following measures.

- Move the digital device away from the affected receiver.
- Reposition (turn) the digital device with respect to the affected receiver.
- Reorient the affected receiver's antenna.
- Plug the digital device into a different AC outlet so the digital device and the receiver are on different branch circuits.
- Disconnect and remove any I/O cables that the digital device does not use. (Unterminated I/O cables are a potential source of high RF emission levels.)
- Plug the digital device into only a grounded outlet receptacle. Do not use AC adapter plugs. (Removing or cutting the line cord ground may increase RF emission levels and may also present a lethal shock hazard to the user.)

If you need additional help, consult your dealer, manufacturer, or an experienced radio or television technician for help.

This device complies with Part 15 of the FCC Rules. Operation is subject to the following two conditions:

- This device may not cause harmful interference.
- This device must accept any interference received, including interference that may cause undesired operation.

**Canadian Regulatory Information** – This equipment complies with the Class B limits for radio noise emissions from digital apparatus as established by the Radio Interference Regulations of the Canadian Department of Communications.

Le présent appareil numérique n'émet pas de bruits radioélectriques dépassant les limites applicables aux appareils numériques de classe B prescrites dans le règlement sur le brouillage radioélectrique édicté par le Ministère des Communications du Canada.

**VDE Manufacturer's Declaration** – Hiermit wird bescheinigt, daß der Z-386SX/20 in Übereinstimmung mit den Bestimmungen der Vfg. 1046/1984 funkentstört ist.

Der Deutschen Bundespost wurde das Inverkehrbringen dieses Gerätes angezeigt und die Berechtigung zur Überprüfung der Serie auf Einhaltung der Bestimmungen eingeräumt.



## Safety Notices for All Users



---

**Caution:** To reduce the risk of electric shock which could cause personal injury, follow all safety notices. The symbols shown are used in your owner's manual and on your equipment to indicate safety hazards.

---

This equipment has a 3-wire, grounded power cord. To prevent electrical hazards, do **not** remove the ground prong on the power cord. Replace the power cord if it gets damaged. Contact your dealer for an exact replacement.

- In the U.S.A. and Canada, the power cord must be a UL-listed detachable power cord (in Canada, CSA-certified), type SV or SVT, 18 AWG, 3-conductor, provided with a molded-on NEMA type 5-15 P plug cap at one end and a molded-on cord connector body at the other end. The cord length must not exceed 15 feet (4.5 meters).
- Outside the U.S.A. and Canada, the plug must be rated for 250 VAC, 10 amp minimum, and must display an international agency approval marking. Consult your dealer or the local electrical authorities if you are unsure of the type of power cord to use in your country.
- The power supply cord is intended to serve as the disconnect device. The socket-outlet shall be near the equipment and shall be easily accessible.
- Das Stromversorgungskabel dient auch zur Notabschaltung. Deshalb sollte sich die Steckdose in der Nähe des Systems befinden und leicht zugänglich sein.

## Safety Notices for Users Outside of the U.S.A. and Canada



---

**Caution:** To reduce the risk of electric shock which could cause personal injury, follow all safety notices. The symbols shown are used in your owner's manual and on your equipment to indicate safety hazards.

---

- **IT System Connectors** – This equipment has not been designed for connection to all IT power systems, a modification may be required. Contact your dealer or local electrical authority.
- **PELV (Protected Extra-Low Voltage) Integrity** – To ensure the extra-low voltage integrity of the equipment, connect only equipment with mains-protected electrically-compatible circuits to the external ports.
- **Remote Earths** – To prevent electrical shock, connect all local (individual office) computers and computer support equipment to the same electrical circuit of the building wiring. If you are unsure, check the building wiring to avoid remote earth conditions.
- **Earth Bonding** – For safe operation, only connect the equipment to a building supply that is in accordance with current wiring regulations in your country. In the U.K., those regulations are the IEE.
- **BABT Notice** – It also complies with BABT's "Apparatus Approval No. NS/G/23/J/100003". With regard to the BT Public Switched Telephone Network OFTEL Statement SA29 refers.

## Care and Handling

Your computer and keyboard may be damaged if not handled carefully. Environmental extremes can also damage them. To protect your computer and keyboard, follow these suggestions:

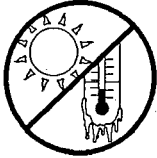

Protect your computer and keyboard from temperature extremes. (Refer to the Specifications section.)



Keep your computer and keyboard away from excessive moisture. (Refer to the Specifications section.)



Keep your computer away from magnetic forces.



Keep your computer and keyboard away from sand and dirt. Cover them when not in use.

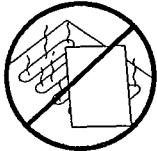

Leave adequate clearance between the air vents and the wall or floor. Allow air to circulate around the back and sides of your computer.

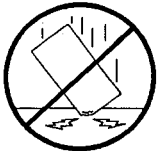

Protect your computer from bumping and dropping.



## **Your Z-386SX/20**

Your desktop computer uses a 20MHz 80386SX microprocessor and includes the following features:

- Numeric coprocessor socket
- VGA video
- 2 megabytes (M) of random-access memory (RAM)
- 64 kilobytes (K) cache memory
- One parallel and one serial port
- PS/2™ mouse port
- Five industry standard expansion slots to allow expansion as your computing needs grow
- Two-level password security protection.

## Using this Manual

The owner's manual is a reference guide for this computer. It provides you with the information necessary to set up, use, and expand your new computer. For information on operating systems and software programs, refer to the documentation that comes with those products.

This manual contains:

- *Chapter 1, Getting Started* — Identifies hardware and tells you how to set up and use your computer.
- *Chapter 2, Keyboard* — Tells you how to use the enhanced keyboard.
- *Chapter 3, Setup* — Shows you how to change the default hardware configurations of your computer.
- *Chapter 4, Hardware Upgrades* — Shows you how to upgrade your computer.
- *Appendix A, Tests and Error Messages* — Tells you how to troubleshoot and test your computer.
- *Appendix B, The Monitor Program* — Describes how to enter and use the Monitor program commands.
- *Appendix C, Backup Battery* — Shows you how to replace the backup battery.
- *Specifications* — Provides technical descriptions and connector pinouts.
- *Glossary* — Defines many of the terms used in this manual.
- *Index* — Provides page-specific topic references.



# Contents

---

---

Chapter 1	Getting Started
Chapter 2	Keyboard
Chapter 3	Setup
Chapter 4	Hardware Upgrades
Appendix A	Tests and Error Messages
Appendix B	The Monitor Program
Appendix C	Backup Battery
	Specifications
	Glossary
	Index



# Chapter 1

# Getting Started

---

---

## Contents

---

Connecting Peripherals . . . . .	1-3
Keyboard . . . . .	1-3
PS/2 Mouse . . . . .	1-3
Video Monitor . . . . .	1-3
Power Cord . . . . .	1-3
Serial Printer or AT Mouse . . . . .	1-4
Parallel Printer . . . . .	1-4
Protecting Your Computer . . . . .	1-5
Powering Up . . . . .	1-6
Operating System . . . . .	1-7



---

---

Refer to this chapter to set up and begin using your computer.

The front panel of your computer contains light emitting diode (LED) indicators and switches. The following illustration and table describe these items.

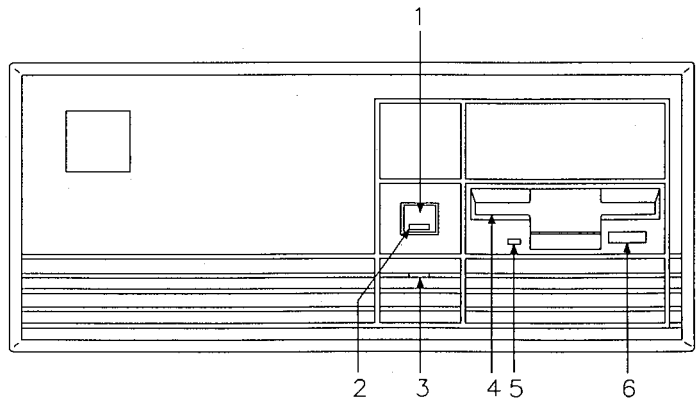

*Front View*

REFERENCE	DESCRIPTION
1	On/Off switch
2	Power LED indicator
3	Hard disk drive LED indicator
4	Floppy disk drive
5	Floppy disk drive LED indicator
6	Disk-eject switch



The back panel of your computer contains ports and security devices. The following illustration and table describe these items.

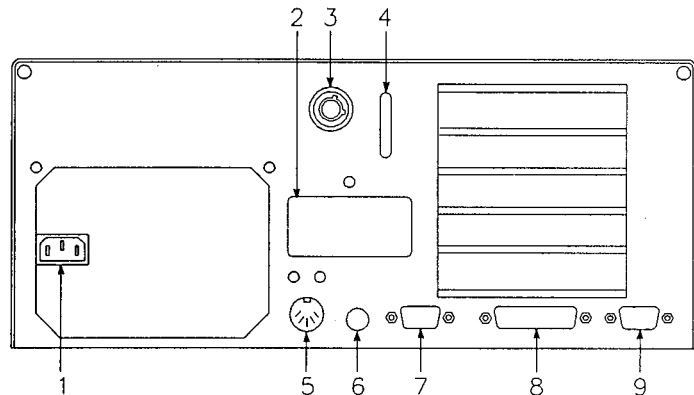

#### *Back View*

REFERENCE	DESCRIPTION
1	Power cord socket
2	Serial board door
3	Cover lock
4	Security loop
5	Keyboard connector
6	PS/2 mouse port
7	Serial port
8	Parallel port
9	Video port

---

## Connecting Peripherals

Use the instructions in this section to connect peripherals to your computer. To connect peripherals, make sure the power is off, then position the computer so that the back panel is accessible.

---

**Notice:** Always make sure the computer is turned off before connecting any peripherals.

---

### Keyboard



Connect the keyboard cable to the keyboard connector on the back of the computer.

### PS/2 Mouse

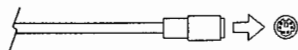

If you have a PS/2 mouse, connect its cable to the mouse port on the back of the computer.

### Video Monitor

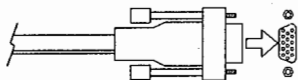

Connect a VGA-type video monitor cable to the video port on the back of the computer, then plug the monitor's power cord into an AC outlet.

### Power Cord

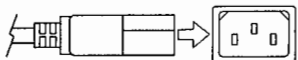

Plug the computer's power cord into the socket on the back of the computer, then plug the other end of the power cord into an AC outlet.

## Serial Printer or AT Mouse

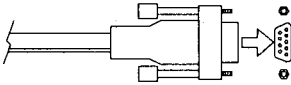

If you have a serial printer or an AT mouse, connect its cable to the serial port on the back of the computer.

## Parallel Printer

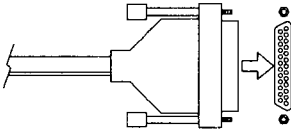

If you have a parallel printer, connect its cable to the parallel port on the back of the computer.

---

## Protecting Your Computer

To protect against tampering and theft, your computer includes a cover lock and a security loop. This section explains how to use these devices.

**Note:** You must have a lockable cable attached to your desk to use the security loop. Suitable cables and mounting hardware are available from most computer supply stores.

To use the cover lock:

1. Remove the key ring with the keys and key tag from the back of the computer.
2. Record the key identification number in a safe place.
3. If you wish to protect the computer's internal components from tampering, lock the computer cover and store the keys and key tag in a safe place.

**Note:** The keys cannot be duplicated. If you wish to order more keys, contact the supplier identified on the key tag. If your keys and identification number are lost, contact your service center.

To use the security loop:

1. Install the cable and mounting hardware on your desk.
2. Pass the cable through the security loop.
3. Lock the cable.

## Powering Up

Once the peripherals are connected to your computer and turned on, power up your computer by pressing the power switch on the front panel.

The power LED indicator lights and the computer performs self-tests and then attempts to boot the operating system. If your computer does not have an operating system installed, you will see one of the following messages:

For hard disk drive models:

```
Not a bootable partition
```

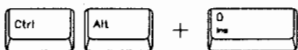

Press the CTRL-ALT-INS key combination in sequence to enter the Monitor program. Refer to the operating system documentation to install the operating system.

For floppy disk drive only models:

```
+++ DISK ERROR: Drive not ready! +++
```



Press the ESC key to enter the Monitor program. Refer to the operating system documentation to install the operating system.

---

## Operating System

An operating system controls all basic functions of the computer. Your computer must have an operating system installed before you can install or use software programs. If an operating system is not installed on your computer's hard disk drive, refer to the operating system documentation for installation instructions.



# Chapter 2

# Keyboard

---

---

## Contents

---

Keyboard Features . . . . .	.2-2
Key Groups . . . . .	.2-3
Alphanumeric Key Group . . . . .	.2-3
Screen and Cursor Control Key Groups . . . . .	.2-4
Numeric Keypad Group . . . . .	.2-5
Function Key Group . . . . .	.2-6
Key Functions . . . . .	.2-7
Key Combinations . . . . .	.2-8



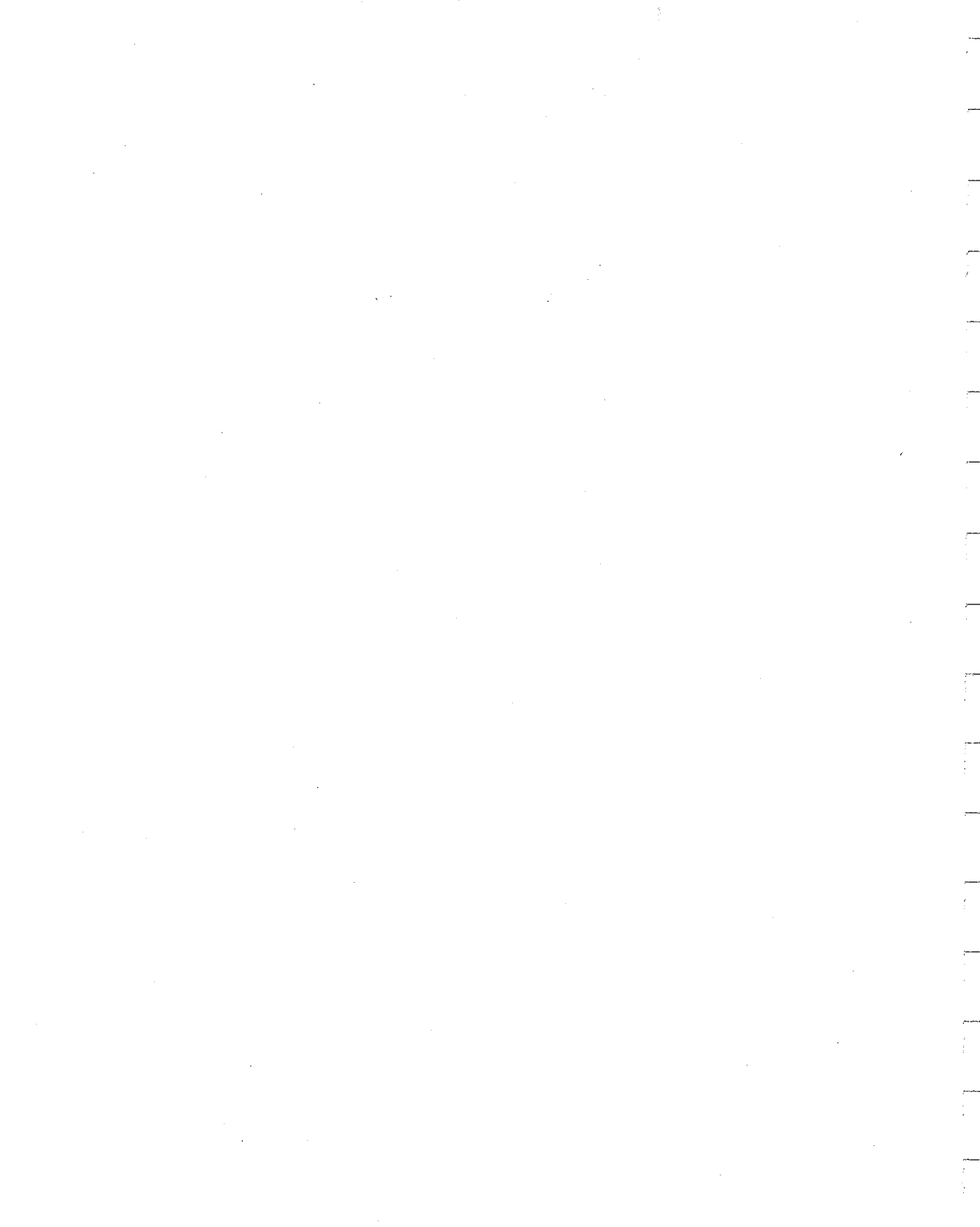

---

Your computer is supplied with an AT-compatible 101-key keyboard. The keyboard is the primary input device used to control computer operation and to enter commands and data.

**Note:** The keyboard is programmable, so some of the key functions described in this chapter may be changed by your operating system or software. Check your software documentation for specific key functions.

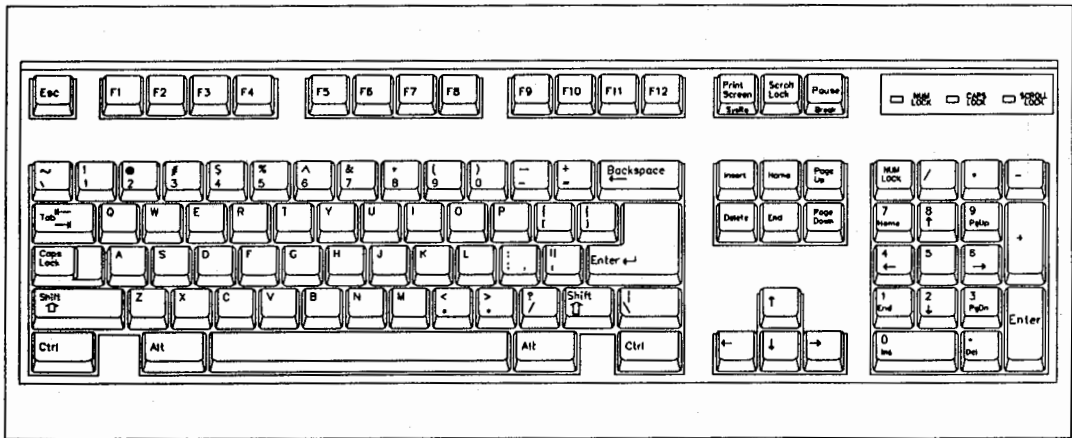

## Keyboard Features

Keyboard features include:

- Automatic key-repetition
- Tactile keys for touch typing
- Key-selectable modes
- Mode status LEDs
- AT compatibility.

Some keys start to repeat when you press and hold them.

The F and J keys and the number 5 key on the numeric keypad have a raised bar on them to help touch typists keep their fingers oriented.

Three status LEDs are located in the upper right corner of the keyboard. When lit, these LEDs indicate the active status of the CAPS LOCK, NUM LOCK, and SCROLL LOCK keys.

## Key Groups

The keyboard keys are arranged in convenient groups:

- Alphanumeric keys
- Screen and cursor control keys
- Numeric keypad keys
- Function keys.

### Alphanumeric Key Group

The alphanumeric key group has character and control keys that resemble a typewriter keyboard.

Character keys include letter, number, punctuation, and space keys.

Control keys include CTRL (control), ALT (alternate), SHIFT, TAB, BACKSPACE, CAPS LOCK, and ENTER/RETURN. When the CAPS LOCK status LED is lit, it indicates when the function is active.

The letter and number keys on the computer keyboard are not interchangeable. Do not type lowercase L ( l ) when you mean a number one ( 1 ) or the capital letter O when you want the number zero ( 0 ).

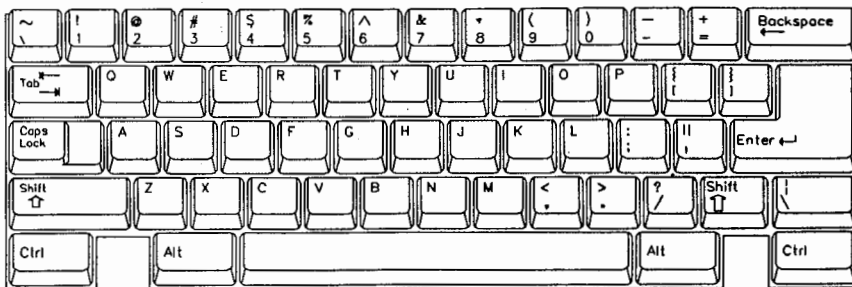

## Screen and Cursor Control Key Groups

The keyboard has two sets of screen control and cursor control keys. One set is part of the numeric keypad group at the far right of the keyboard (active when the NUM LOCK status LED is off), and the other set is located between the alphanumeric key group and the numeric keypad group. Both sets are used to control screen presentation.

Screen control keys include INSERT, DELETE, HOME, END, PAGE UP, PAGE DOWN, PRINT SCREEN/SYSRQ (system request), SCROLL LOCK, and PAUSE/BREAK. When the SCROLL LOCK status LED is on, the scroll lock function is active.

Cursor control keys include the left, right, up, and down arrow keys.

**Note:** Your operating system or software may use both sets of screen control and cursor control keys. Other software may use only the screen control and cursor control keys that are part of the numeric keypad.

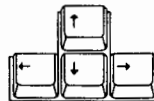

## Numeric Keypad Group

The numeric keypad has mathematical operator keys, numeric keys, and control keys. The numeric keys are active when the NUM LOCK status LED is on. The control keys are active when the NUM LOCK status LED is off.

- Mathematical operators include division ( / ), multiplication ( \* ), subtraction ( - ), and addition ( + ).
- Numeric keys include the numbers 0 through 9, and a decimal point.
- Control keys include NUM LOCK (number lock), ENTER, HOME, END, PG UP (page up), PG DN (page down), INS (insert), DEL (delete), and arrow keys.

The keypad numeric keys are arranged like a calculator keypad for rapid data entry.



## Function Key Group

The function keys include twelve programmable keys, three dedicated function keys, and the ESC key.

- Programmable keys include F1 through F12.
- Dedicated function keys include PRINT SCREEN/SYSRQ (system request), SCROLL LOCK, and PAUSE/BREAK.
- ESC usually halts or exits a program.

The PRINT SCREEN function sends the screen display to the printer port. SYSRQ accommodates software programs that use a system request.

Press the SCROLL LOCK key to stop information scrolling on the screen. Press it again to continue scrolling. The SCROLL LOCK status LED indicates when that function is active.

The PAUSE/BREAK key halts program execution.

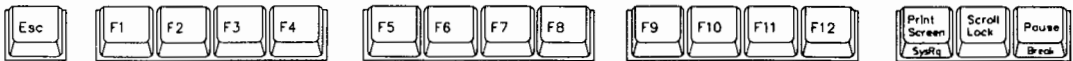

## Key Functions

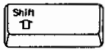

SHIFT affects alphanumeric letter, number, and punctuation keys. Either SHIFT key enables capital letters, symbols, and alternate punctuation marks. If CAPS LOCK is on (the CAPS LOCK status LED is lit) and you press SHIFT, lowercase characters are produced.



CAPS LOCK is similar to a typewriter shift lock key, but it affects only the letter keys. Press it once to begin typing capital letters, press it again to stop typing capital letters. When CAPS LOCK is on (status LED is lit), pressing either SHIFT key generates lowercase letters on the letter keys.

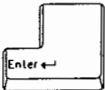

The ENTER/RETURN key (and the ENTER key on the numeric keypad) completes keyboard entries. Press ENTER when you finish entering data or commands to tell the computer to process them.



The TAB key moves the cursor to the next tab setting. The next tab setting may be a specific number of spaces (usually five) in the line you are typing, or it may be a new data field on the screen.

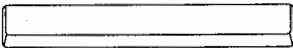

When typing commands and data, use the space bar to enter a blank space.



The BACKSPACE key moves the cursor to the left, erasing any characters in the cursor's path. Software programs may also use it to change text on the screen or move the cursor without erasing any characters.



## Key Combinations

The CTRL and ALT keys can be used with other keys to issue commands. Sometimes both keys are used in conjunction with a third key. To use a CTRL or ALT key, press and hold it, then press another key. Some common CTRL and ALT key commands are:

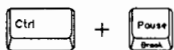

CTRL-BREAK halts program execution.

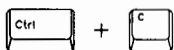

CTRL-C halts program execution. This command may not be recognized by some software programs.



CTRL-ALT-DEL resets the computer, initiates the power-up self-tests, and then autoboots the computer (if the computer is configured to autoboot).

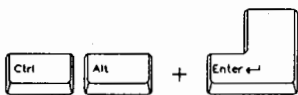

CTRL-ALT-ENTER displays the contents of the CPU's registers and flags, and then enters the Monitor program. Press G and ENTER to return to the operating system or your software program.



CTRL-ALT-INS resets the computer, initiates the power-up self-tests, and then enters the Monitor program. This command overrides autoboot.

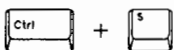

CTRL-S stops output to the screen until you press another key. This command is generally used to stop scrolling.

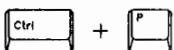

CTRL-P toggles the "printer echo" function on and off. When printer echo is on, text displayed on the screen is also printed by the printer.

**Contents**

---

Entering Setup . . . . .	3-2
Using Setup . . . . .	3-3
Time and Date . . . . .	3-6
Memory Configuration . . . . .	3-8
Disk Drives . . . . .	3-10
Video . . . . .	3-13
Operating Speed and Cache Selection . . . . .	3-14
Boot Options . . . . .	3-16
Communications Ports . . . . .	3-17
Password Options . . . . .	3-18
Exiting Setup . . . . .	3-23



---

---

The Setup program allows you to specify how the hardware in your computer operates. System clock, memory, disk drives, video, operating speed and cache selection, boot procedures, communication ports, and passwords are hardware features of the computer that you can configure.

All of the hardware features have a default configuration that is effective when you turn on the computer. You do not need to change the default configuration until you customize your computer. Refer to the instructions in this chapter to change a setting.

**Note:** If you make any changes in the hardware configuration, save the new configuration when you exit the Setup program. Otherwise, all your changes will be lost.

## Entering Setup



The Setup program is part of the Monitor program. To access the Monitor program, press the CTRL-ALT-INS key combination in sequence. You will see the Monitor prompt:

```
MFM-300 Version x.xx  
Memory Size: xxxK + xxxK + xxK Cache  
Enter "?" for help.  
->
```

When the Monitor prompt appears, type SETUP and press ENTER.

## Using Setup

The System Setup Menu, shown below, displays all of the items that can be changed. To select an item, use the arrow keys to highlight your selection and press ENTER.

**S Y S T E M   S E T U P   M E N U**

Time/Date	Operating Speed
Memory Configuration	Boot Options
Disk Drives	Communication Devices
Video	Password

Press <ENTER> to select this item

Set the System Time and Date

Arrows: move    Space/Bkspc: change option    <ENTER>: selects    <ESC>: exit

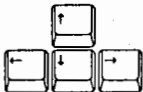

When the menu appears, use the arrow keys to highlight the item you wish to change.

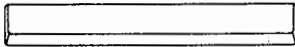

Use the space bar or BACKSPACE key to scroll through the available options.



Press the ESC key when finished.

The menu maps on the following pages provide a visual guide for using the Setup program.

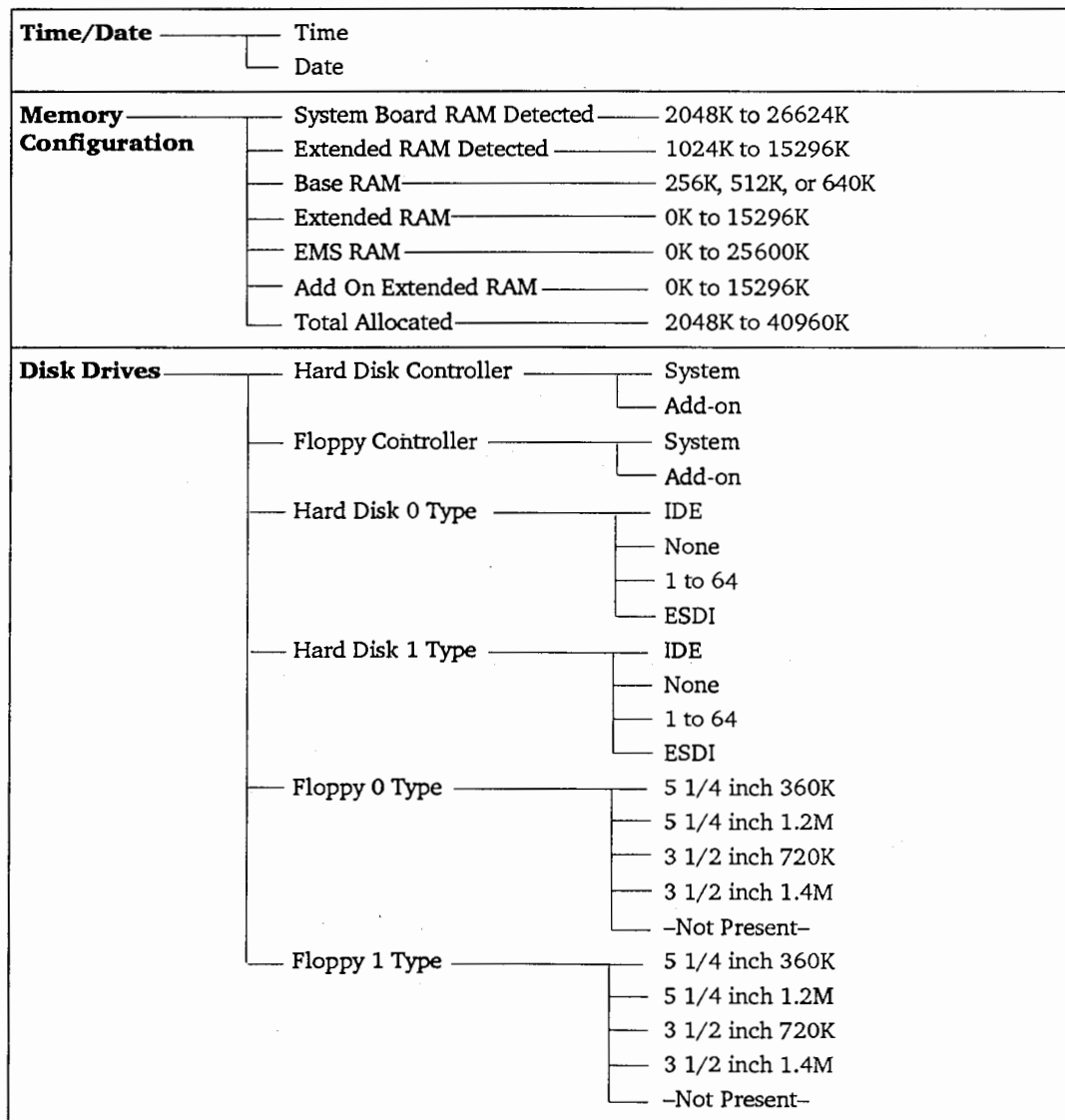

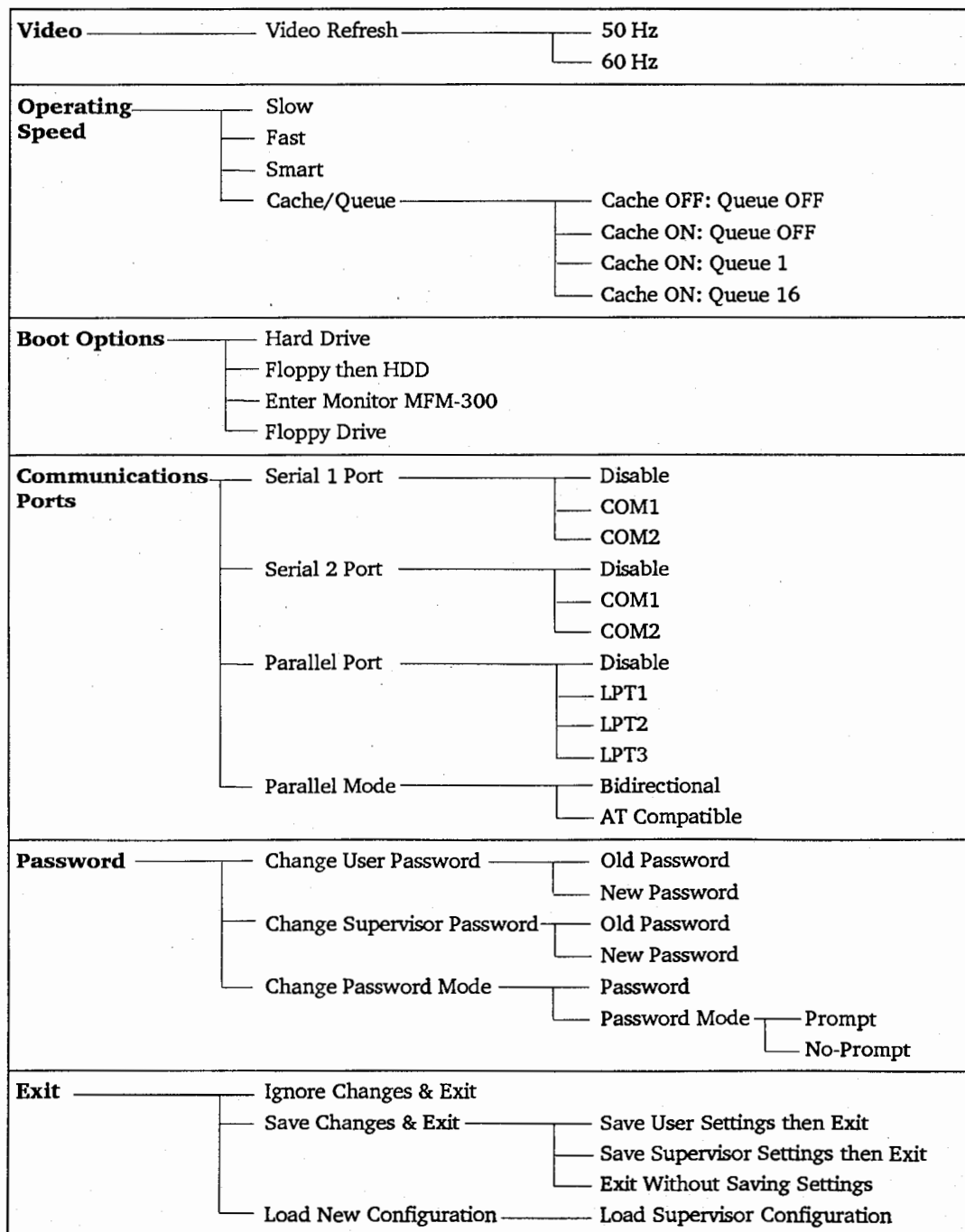



## Time and Date

<b>Time/Date</b> ————	Time
	Date

The computer's clock and calendar run continuously to keep accurate track of the time and date. When the computer is turned off, the RTC (real-time clock) battery keeps the clock running. Enter the time and date only when you turn on the computer for the first time, or when the RTC battery is replaced.

**Time** — The computer's real-time clock operates on a 24-hour format. For example, 2:00 PM is 14:00, and 11:00 PM is 23:00. The format for entering time is hours-minutes-seconds. You must enter a leading zero (0) if the hours or minutes have one digit. If you make an incorrect entry, the following message appears on the screen:

```
INVALID TIME: Hr=00-23, Min=00-59, Sec=00-59. ESC to continue.
```

Enter the correct time in the proper format.

Examples:

For 4:35 AM, enter 043500

For 4:35 PM, enter 163500

The last two zeroes are optional. Press ENTER to move to the Date field after the time is set.

---

**Date** – The computer tracks the date using months (01-12), days (0-31), and years. The format for entering the date is month-day-year. You must enter a leading zero (0) if the month or day has only one digit. If you make an incorrect entry, the following message appears on the screen:

INVALID DATE: Mon=01-12, Day=01-Max/Mon, Yr=1900-2099. Esc to cont.

**Examples:**

For April 25, 1992, enter 04251992

For May 24, 1992, enter 05241992

After setting the date, press ESC to return to the Setup menu.

## Memory Configuration

<b>Memory Configuration</b>	System Board RAM Detected	2048K to 26624K
	Extended RAM Detected	1024K to 15296K
	Base RAM	256K, 512K, or 640K
	Extended RAM	0K to 15296K
	EMS RAM	0K to 25600K
	Add On Extended RAM	0K to 15296K
	Total Allocated	2048K to 40960K

This menu allows you to configure your computer's memory. To meet the needs of different software programs, you can change three fields: Base RAM, Extended RAM, and EMS RAM.

**System Board RAM Detected** – This field reports the amount of RAM installed on the system board. This field is for information only and cannot be changed.

**Extended RAM Detected** – This field reports the total amount of extended RAM available for use. This field is for information only and cannot be changed.

**Base RAM** – This is the amount of memory designated as base memory.

---

**Extended RAM** – Memory between 1M and 16M can be configured as extended RAM. Memory over 16M must be configured as EMS RAM. Extended RAM is allocated in 1M units.

**Note:** Memory cards installed on the backplane board can only be configured as Extended RAM.

**EMS RAM** – Memory between 1M and 26M can be configured as EMS RAM. EMS RAM is allocated in 1M units.

**Add-on Extended RAM** – This field reports the total amount of add-on extended RAM on a memory card. This field is for information only and cannot be changed.

**Total Allocated** – This field reports the total amount of memory available for use. This is the sum of the Base RAM, Extended RAM, EMS RAM, and Add-on Extended RAM. This field is for information only and cannot be changed.

## Disk Drives

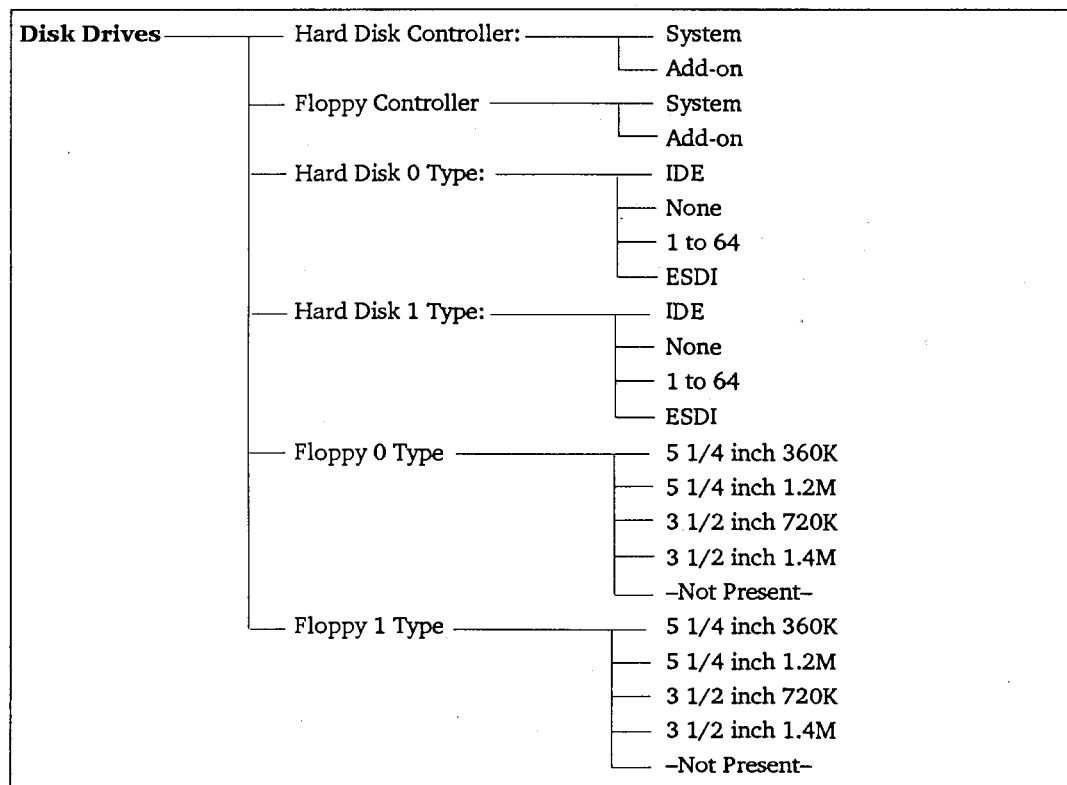

This menu is used to tell the computer the locations of the hard drive controller and the floppy drive controller. It is also used to tell the computer what type of hard and floppy disk drives are installed.

---

## Hard Disk Drive

**Hard Disk Controller** – This field indicates the location of the hard disk drive controller. The available locations are:

System – Indicates that the hard disk controller is part of the system board.

Add-on – Indicates that the hard disk controller is part of an add-on card. The hard disk drive is connected to the add-on card.

**Hard Disk 0 Type** – This field indicates the type of hard disk drive installed in your computer. The available drive options are:

IDE – For an integrated drive electronics (IDE ) hard disk drive.

None – For no hard disk drive or for a small computer system interface (SCSI) hard disk drive.

1 to 64 – For an ST-506 hard disk drive.

ESDI – For an enhanced small device interface (ESDI) hard disk drive.

**Hard Disk 1 Type** – This field has the same available options as Hard Disk 0 Type, but is used only if a second hard disk drive is installed.

**Note:** Before installing a hard disk drive, contact your service center for approved hard disk drives.

## Floppy Disk Drive

**Floppy Controller** – This field indicates the location of the floppy disk drive controller. The available locations are:

System – Indicates that the floppy disk controller is part of the system board.

Add-on – Indicates that the floppy disk controller is part of an add-on card. The floppy disk drive is connected to the add-on card.

**Floppy 0 Type** – This field indicates the type of floppy disk drive installed in your computer. The available drive options are:

3.5 inch 720K

3.5 inch 1.4M

5.25 inch 360K

5.25 inch 1.2M

-Not Present-

**Floppy 1 Type** – This field has the same available options as Floppy 0 Type, but is used only if a second floppy disk drive is installed.

## Video

<b>Video</b> _____ Video Refresh _____	50 Hz
	60 Hz

This menu is used to select the video refresh rate.

**Video Refresh** – The available options for this field are:

50 Hz – Use this option if you are in Europe.

60 Hz – Use this option if you are in the United States or Canada.

If the wrong video refresh rate is selected, the video display may flicker.



## Operating Speed and Cache Selection

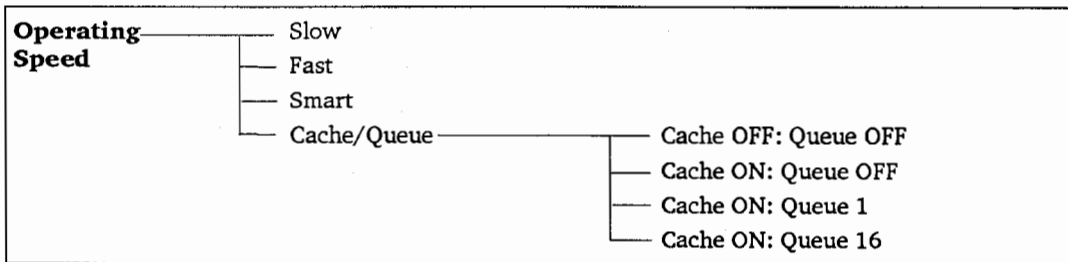

This menu is used to select the operating speed and cache configuration of your computer.

### Operating Speed

**Slow** – Computer speed is reduced to 10 MHz for software compatibility. Choose this setting if your software program does not operate properly in the Fast or Smart settings.

**Fast** – Computer speed is maximized at 20 MHz for time-sensitive applications. Most software will run at this setting.

**Smart** – Computer speed is reduced to 10 MHz during floppy disk drive access. Other operations remain at 20 MHz. Choose this setting if your software program does not operate properly in the Fast setting.

## Cache/Queue

This field allows you to configure the cache memory and instruction queue. Cache is a block of high-speed memory that stores commands and data from RAM, allowing the microprocessor to quickly access the information. Up to 64K of information can be stored in the cache.

The instruction queue speeds up computer operation by storing data and instructions (while the microprocessor continues program execution) until it can be transferred to RAM. Up to 16 sets of data and instructions can be stored in the instruction queue.

Since cache memory and the instruction queue speed up your computer, some older software programs may not run with the cache and queue fields enabled. If your computer experiences problems when running an older software program, first slow the computer down by using smart or slow mode as described earlier. If your computer still experiences problems, try setting the instruction queue to 1 or OFF. As a last resort, turn the cache off so the computer operates as slowly as possible.

**Cache ON : Queue OFF** – Cache is enabled, but with no queue enhancement. This setting improves the system efficiency with minimal impact on software compatibility.

**Cache ON : Queue 1** – Cache and the queue enhancement are activated with one buffer within the queue. Choose this setting if the software program requires only one buffer.

**Cache ON : Queue 16** – Cache and the queue enhancement are activated with 16 buffers within the queue. This setting maximizes system performance.

**Cache OFF : Queue OFF** – Cache is disabled.

## Boot Options

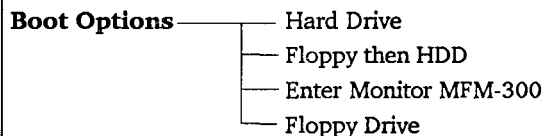

This menu allows you to determine if the computer will attempt to boot the operating system or enter the Monitor program at power up.

**Hard Drive** — The computer boots the operating system from the hard disk drive.

**Floppy then HDD** — The computer first tries to boot the operating system from floppy disk drive 0. If no disk is installed, the computer boots from the hard disk drive.

If a floppy disk is installed, but is not bootable, the computer will halt and display:

Non-system disk

Remove the floppy disk and reset the computer.

**Enter Monitor MFM-300** — The computer does not boot the operating system. Instead, it enters the Monitor program.

**Floppy Drive** — The computer will attempt to boot the operating system from floppy disk drive 0. If no disk is installed or if the disk is not bootable, the computer displays an error message.

## Communications Ports

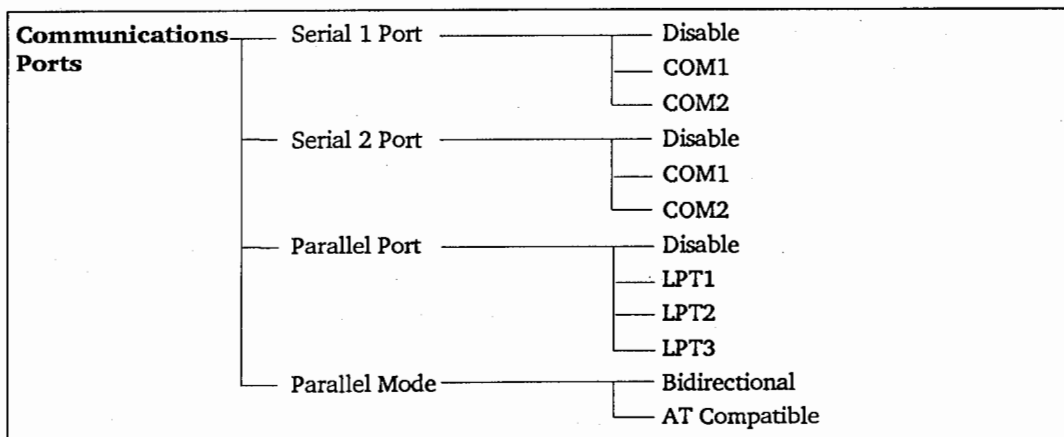

This computer comes equipped with two communications ports: one serial port and one parallel port. An optional serial port may also be installed. This menu allows you to configure each port so that the computer can communicate with it. It also allows you to specify the type of parallel peripheral used.

**Serial 1 Port** – This port can be configured as COM1, COM2, or disabled.

**Serial 2 Port** – This optional port can be configured as COM 1, COM 2, or disabled.

**Parallel Port** – This port can be configured as LPT1, LPT2, LPT3, or disabled.

**Parallel Mode** – This field allows you to configure the parallel port as either bidirectional or AT compatible.

## Password Options

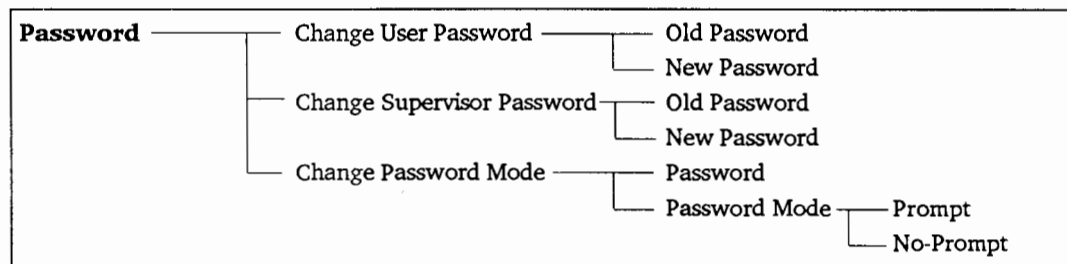

This menu allows you to establish two passwords. Each protects different levels of computer operation.

---

**Notice:** If you set a password, be sure to remember it. If you forget your User password, you can disable it with your Supervisor password. If you forget your Supervisor password, you must take your computer to a service center to have the password cleared.

---

**User Password** – This is a power-up password that protects your computer from unauthorized use. Once set, you must enter this password each time you power up or reset the computer. Your User password allows access to most computer operations. It cannot be used to change a Supervisor password or to store configuration information to electrically erasable programmable read-only memory (EEPROM) when a Supervisor password is set.

**Supervisor Password** – This is a configuration password that overrides the User password, and protects configuration information stored in EEPROM. Once set, you are prompted for the Supervisor password when you save Setup changes to the Supervisor Configuration. The Supervisor password can also be used for a power up password and for disabling or changing a User password.

---

**Password Mode** – You can select either the *Prompt* or *No-Prompt* option with this field. With the *Prompt* option, the computer will ask you for a password before booting the operating system or entering the Monitor program. With the *No-Prompt* option, the computer will boot the operating system or enter the Monitor program, but will lock the keyboard until the proper password is entered.

You can use any alphanumeric keys for your password. Alphanumeric characters include all punctuation, special characters, and the space bar. Do not use the SHIFT or CAPS LOCK keys when entering the password.

To stop a password entry, press the ESC key. To correct a mistake, use the BACKSPACE key (not the arrow keys) to delete incorrect characters.

## Setting a Password

Enter the Setup program as previously described.

1. Select *Password* from the System Setup Menu.
2. Select *Change User Password* or *Change Supervisor Password* from the Password Options Menu.
3. When the highlight appears on the *New Password* line, type a password of eight characters or less and press ENTER. For security reasons, the characters you type do not appear on the screen; the cursor moves and the x's are replaced with blocks.
4. To verify the password, you must retype the password exactly as it was entered the first time, and press ENTER. Your new password takes effect immediately.

If you do not spell the password the same both times, the following message is displayed:

```
Password Mismatch!! Enter your new password again! ESC to continue.
```

Press ESC and carefully re-enter your password, then press ENTER.

After you have successfully entered your password, the highlight moves back to the Password Options Menu.

**5.** Press ESC to return to the System Setup Menu.

If the following message appears, contact your service representative:

```
Cannot modify password! EEPROM is probably bad! ESC to continue.
```

Once the User password is set, you have five chances to type the correct password and access the system. After five unsuccessful attempts, the computer halts and displays:

```
+++ Password Security Violation: System Shutdown +++
```

Turn off the computer for at least 15 seconds, then turn it back on. Enter the password again.

---

## Changing a Password

Enter the Setup program as previously described.

1. Select *Password* from the System Setup Menu.
2. Select *Change User Password* or *Change Supervisor Password*.
3. When the highlight appears on the *Old Password:* xxxxxxxx line, type your current password and press ENTER. The cursor moves to *New Password:* xxxxxxxx xxxxxxxx.

Proceed through the remainder of the steps as if you were entering a password for the first time. Your new password takes effect immediately.

## Disabling the User Password

The User password can be cleared if you know the User password or the Supervisor password.

1. Select *Password* from the System Setup Menu.
2. Select *Change User Password*.
3. When the highlight appears on the *Old Password:* xxxxxxxx line, type the Supervisor or User password and press ENTER. The cursor moves to *New Password:* xxxxxxxx xxxxxxxx.
4. Press ENTER twice to disable the User password.

You no longer will be required to enter a password when you power up or reset your computer.



## Disabling the Supervisor Password

1. Select *Password* from the System Setup Menu.
2. Select *Change Supervisor Password*.
3. When the highlight appears on the *Old Password: xxxxxxxx* line, type your Supervisor password and press ENTER. The cursor moves to *New Password: xxxxxxxx xxxxxxxx*.
4. Press ENTER twice to disable the password.

You are no longer required to enter a password when saving a new configuration to the Supervisor Configuration.

## Exiting Setup

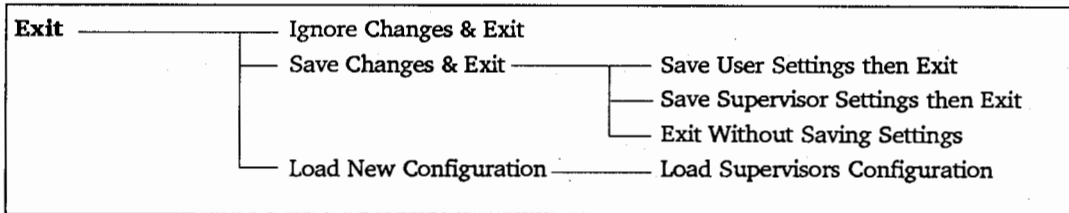

When you exit the Setup program, you must choose whether you want to discard any changes made, save the changes as a new configuration, or load a previously defined configuration.

Press ESC at the System Setup Menu to exit from the Setup program.

Use the arrow keys to move the highlight to your selection and press ENTER.

### Ignore Changes

Select *Ignore Changes & Exit* if you want to discard all changes that you have made. The current configurations remain unchanged.

### Save Changes

Select *Save Changes & Exit* if you have made changes to Setup and wish to save them:

**Save User Settings then Exit** – This selection saves the changes to CMOS RAM before exiting.

**Save Supervisor Settings then Exit** – This selection saves the changes to CMOS RAM and EEPROM.

If the supervisor password is set, the computer displays the following prompt if you attempt to save the configuration information to permanent memory:

Supervisor Password: xxxxxxxx

If you type the wrong password, the following message is displayed:

Password Mismatch!! Enter your current password again! Esc to continue.

Press ESC and re-enter your password. After five unsuccessful attempts, the following message is displayed:

Too many tries!! Request is denied! Esc to continue.

Press ESC to return to the Monitor prompt. The changes you made are discarded.

**Exit Without Saving Settings** – This selection allows you to change your mind and returns you to the Setup exit menu.

### **Load New Configuration**

Select *Load New Configuration* if you wish to replace the configuration in CMOS RAM with the configuration in EEPROM. When you choose this option, you are prompted with:

**Load Supervisor Configuration** – This selection loads the configuration information currently stored in EEPROM.

# Chapter 4

## Hardware Upgrades

---

---

### Contents

---

Static Precautions . . . . .	4-2
Removing the Cover . . . . .	4-3
Adding Options . . . . .	4-5
Serial Board . . . . .	4-5
Numeric Coprocessor . . . . .	4-8
Memory . . . . .	4-10
Disk Drives . . . . .	4-12
Circuit Cards . . . . .	4-24
Replacing the Cover . . . . .	4-27
Computer Stand . . . . .	4-29



---

---

This chapter provides instructions for upgrading your computer's hardware. You can install the options yourself, or you can have your service representative install them for you.

The following options are available for your computer:

- Serial board — Adds a second serial port to your computer.
- Numeric coprocessor — Speeds up calculations for applications such as spreadsheet and drafting programs.
- Memory expansion — Allows programs to run that require additional memory.
- Disk drives — Increases your computer's storage capacity.
- Circuit cards — Expand your computer's capabilities.
- TIGA™ video card — Improves video resolution and speed.
- Computer stand — Arranges your computer vertically.

Contact your sales representative for information on other options available for this computer.

## Static Precautions

Circuit cards and ICs (integrated circuits) can be easily damaged by static electricity. To prevent damage, keep them in protective packaging when they are not installed in your computer.

When installing or removing SIMMs (single in-line memory modules), disk drives, circuit cards, or other devices, protect them from static electricity. Before picking up the device, equalize the static electricity between the work surface and the device by touching the work surface with one hand and touching the device with the other. Do not set the device down or let go of it until it is installed in the computer.

## Removing the Cover



---

**Caution:** Hazardous voltages are present inside the computer when it is connected to the AC supply, even when the power switch on the computer is set to OFF. These voltages could cause personal injury. To avoid injury during service, maintenance, or adding enhancements, disconnect the power cord from the AC outlet and disconnect all peripherals from the computer before removing the computer cover.

---

To remove the cover:

1. Turn off the computer.
2. Unplug the power cord from the AC outlet.
3. Turn off the video monitor and peripherals.
4. Disconnect the video monitor and peripherals from the computer.
5. Disconnect the keyboard cable from the back of the computer.
6. Unlock the cover with the key provided with the computer.

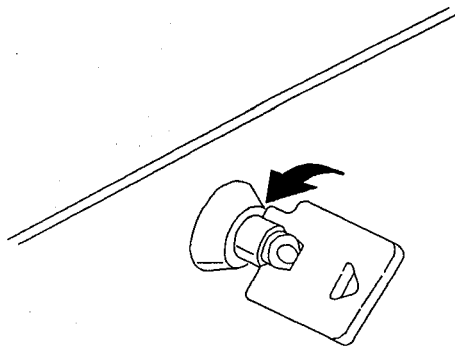



7. Remove the two thumbscrews that hold the cover to the chassis.

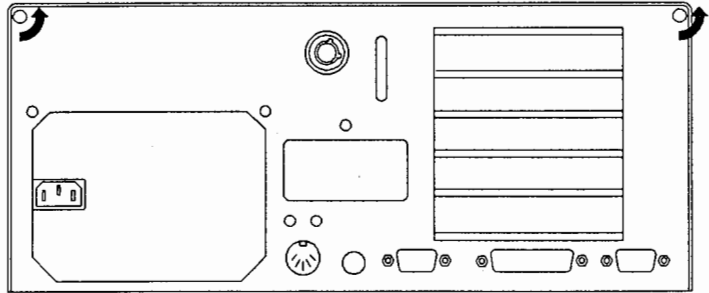

8. Facing the front of the computer, slide the cover toward you.
9. Lift up on the back of the cover and remove it from the computer.

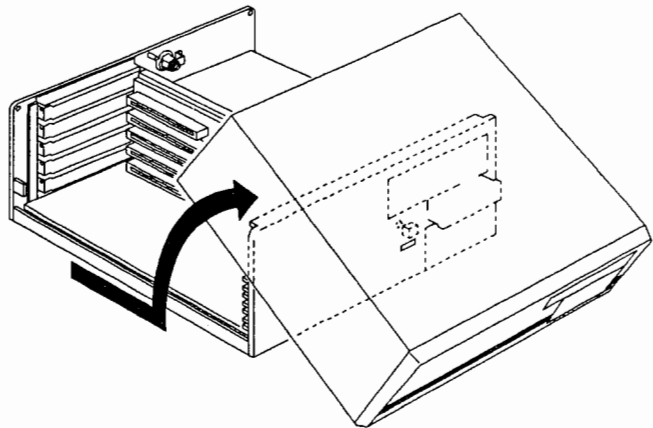

## Adding Options

The following sections provide instructions for installing options in your computer.

### Serial Board

To install the serial board:

1. Remove the cover as described earlier.
2. With a phillips screwdriver, remove the screw that holds the serial board door in place. Save the screw for later use.
3. Remove the serial board door from the back panel of the computer. Save the serial board door in case you ever remove the serial board.

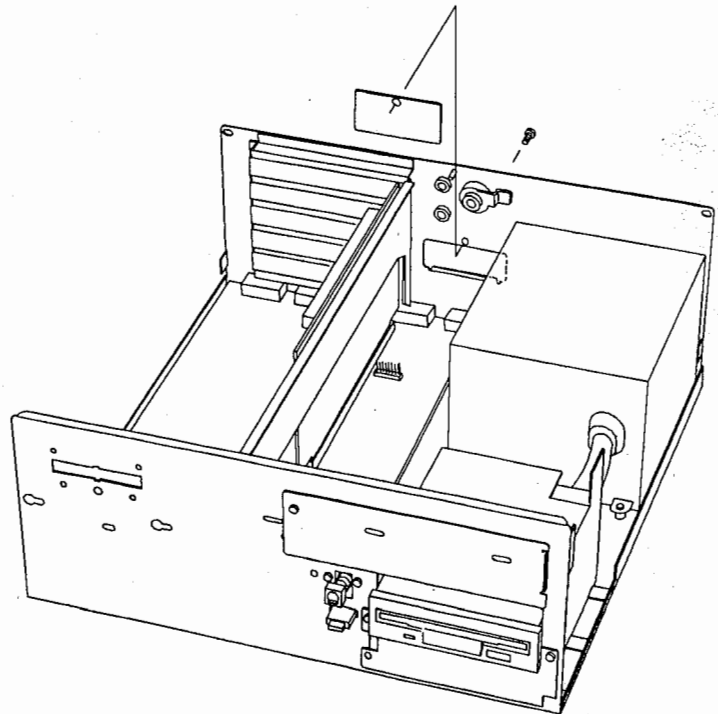

---

**Notice:** Observe static precautions.

---

4. Remove the serial board from its packaging.
5. With the red stripe on the serial board ribbon cable towards the power supply, plug the ribbon cable into P114 on the system board.

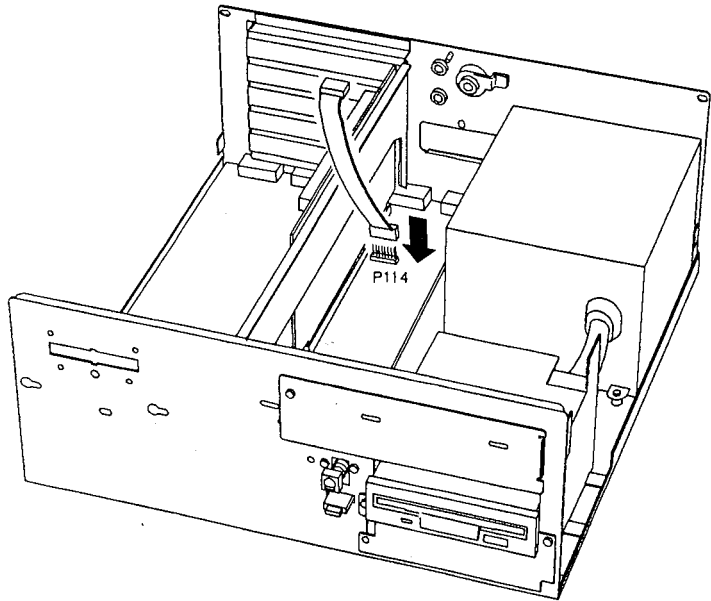

6. Install the serial board in the opening in the back panel and secure it with the screw saved in step 2.

7. With the red stripe facing the power supply, plug the free end of the ribbon cable into the serial board.

**Note:** Make sure you route the ribbon cable so that it is not pinched by a circuit card or other installed options.

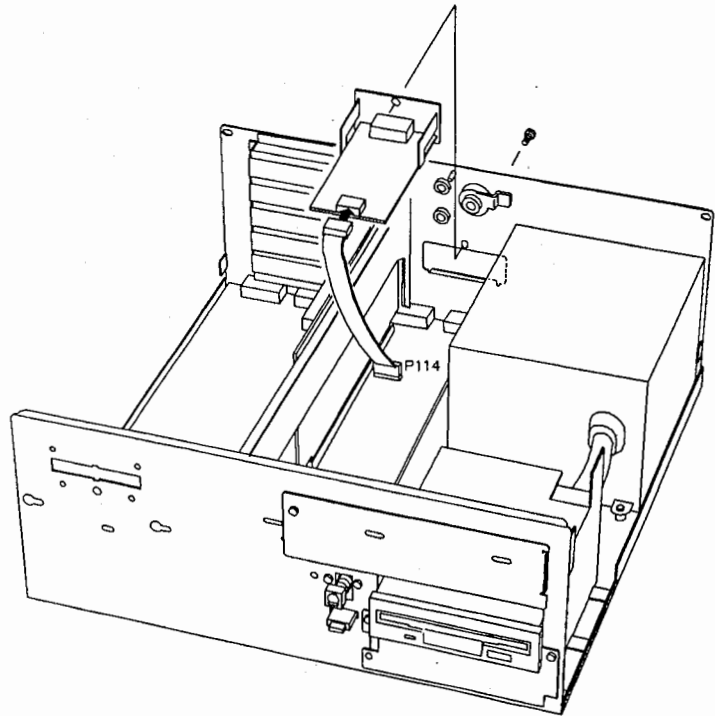

8. Replace the cover as described in the “Replacing the Cover” section later in this chapter.
9. Change the Communication Ports in the Setup program so that the computer recognizes the added serial port. Refer to the Setup chapter for more information.

## Numeric Coprocessor

See the Specifications chapter for the appropriate numeric coprocessor.

To install the coprocessor:

1. Remove the cover as described earlier.

---

**Notice:** Observe static precautions.

---

2. If a full-length circuit card is installed in expansion slot P304 on the backplane board, remove it so you can access the coprocessor socket.

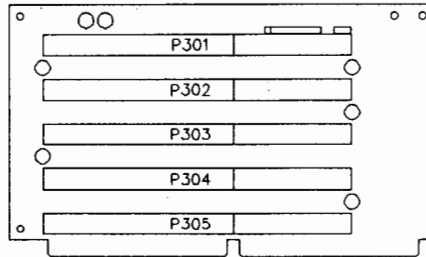

3. Locate the coprocessor socket (U102) on the system board.

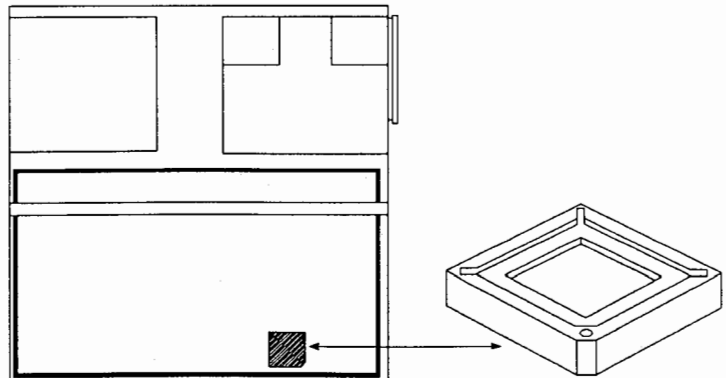

---

**Notice:** Observe static precautions.

---

4. Remove the coprocessor from its protective packaging.
5. With one hand touching a metal portion of the computer, position the coprocessor above the socket.
6. Make sure the notched corner of the coprocessor and the notched corner of the socket are lined up, then press the coprocessor firmly into the socket.

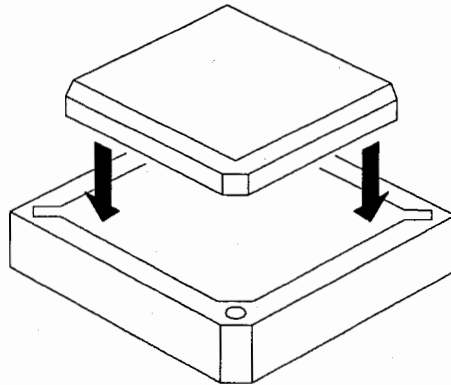

7. Reinstall the circuit card if removed earlier.
8. Replace the cover as described in the "Replacing the Cover" section later in this chapter.

## Memory

Your computer was shipped from the factory with 2M of RAM soldered to the system board in memory bank 0. The RAM can be increased by installing SIMMs (single in-line memory modules) in memory banks 1, 2, and 3 on the system board.

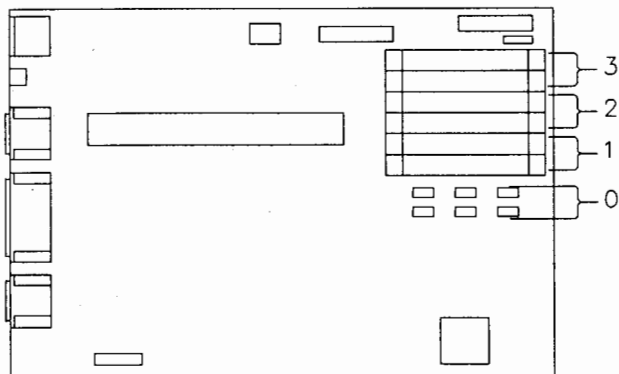

You can add three types of SIMMs to the memory banks on the system board: 256K, 1M, and 4M. SIMMs must be installed in pairs according to the configuration in the following table. For example, if you want to upgrade your memory to 12M, you must install two 1M SIMMs in bank 1, and two 4M SIMMs in bank 2.

### *SIMM Configurations*

Total Memory	Bank 0 <sup>1</sup>	Bank 1		Bank 2		Bank 3	
2M	2M	-	-	-	-	-	-
3M	2M	256K	256K	256K	256K	-	-
4M	2M	1M	1M	-	-	-	-
5M	2M	1M	1M	256K	256K	256K	256K
6M	2M	1M	1M	1M	1M	-	-
8M	2M	1M	1M	1M	1M	1M	1M
10M	2M	4M	4M	-	-	-	-
12M	2M	1M	1M	4M	4M	-	-
18M <sup>2</sup>	2M	4M	4M	4M	4M	-	-
26M <sup>2</sup>	2M	4M	4M	4M	4M	4M	4M

#### **NOTES**

1. This bank contains 2M of factory installed RAM.
2. Memory over 16M must be configured as EMS RAM in the Setup program.

To install SIMMs:

1. Remove the cover as described earlier.

---

**Notice:** Observe static precautions.

---

2. Remove the SIMM from its protective packaging.
3. With one hand touching a metal portion of the computer, position the SIMM so that the edge connector is over the socket and the memory devices are facing the opposite direction of the drive bay.
4. Tilt the top of the SIMM slightly toward the drive chassis and guide it into its socket, then gently push it to its upright position until it clicks into place.

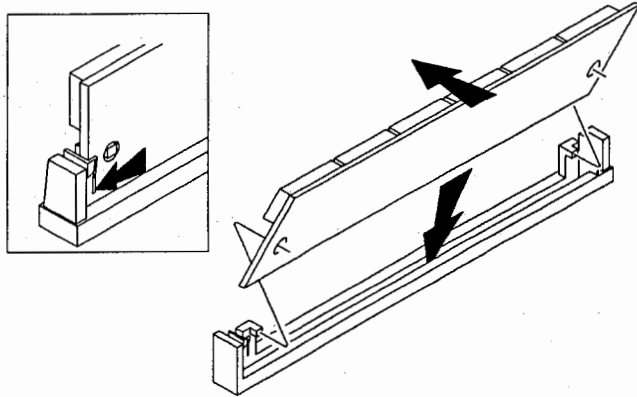

5. Replace the cover as described in the “Replacing the Cover” section later in this chapter.
6. Change the Memory Configuration in the Setup program so that the computer recognizes the added memory. Refer to the Setup chapter for more information.
7. Perform the base memory and extended memory tests to verify that all memory banks are functioning properly. Refer to the Tests and Error Messages appendix for more information.



## Disk Drives

Your computer's drive bay can support a maximum of three disk drives. The following illustration and table describe the drive bay.

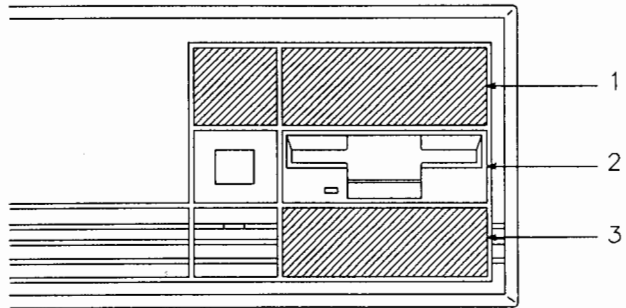

REFERENCE	DESCRIPTION
1 (Top)	Can accommodate a 5.25-inch half-height floppy disk drive or a 3.5-inch floppy disk drive.
2 (Middle)	Contains a 3.5-inch floppy disk drive.
3 (Bottom)	Contains an optional 3.5-inch hard disk drive.

## Floppy Disk Drive

To install a floppy disk drive in the top drive bay:

1. Remove the cover as described earlier.
2. Remove the top drive bay cover. Replace the screw that held the cover in place.

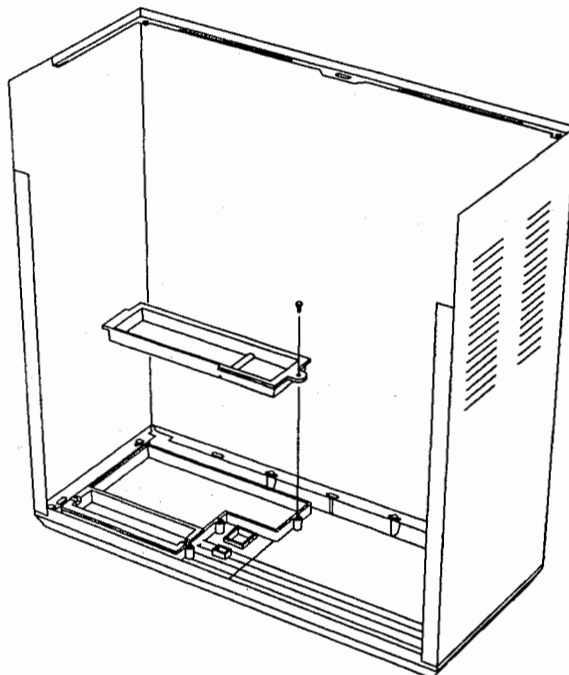

3. Remove the bracket covering the top drive bay. Save the bracket for later use.

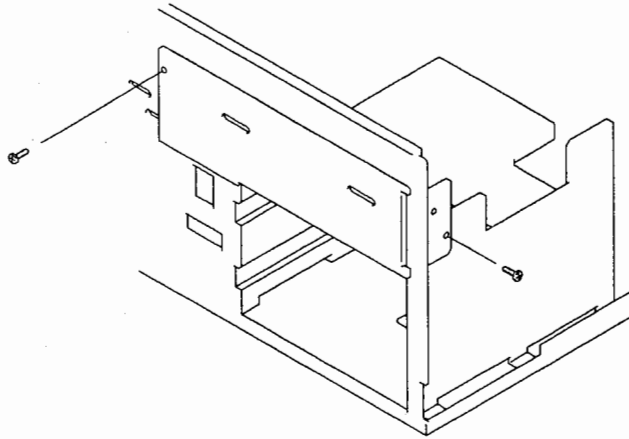

---

**Notice:** Observe static precautions.

---

4. Remove the floppy disk drive from its protective packaging.
5. If you are installing a 3.5-inch floppy disk drive, attach the drive adapter mounting bracket to the new drive.

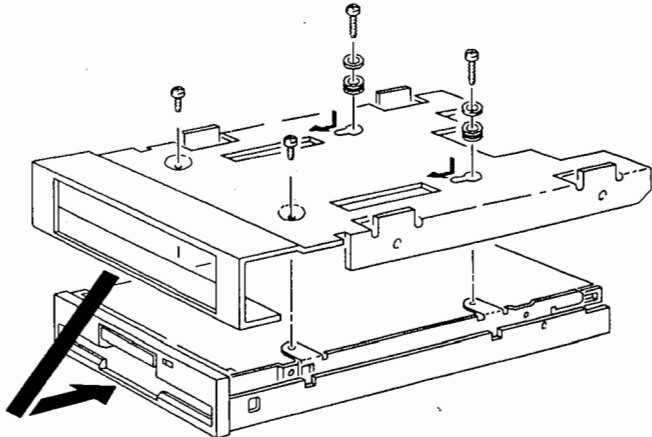

6. Attach the bracket you removed earlier to the side of the drive.

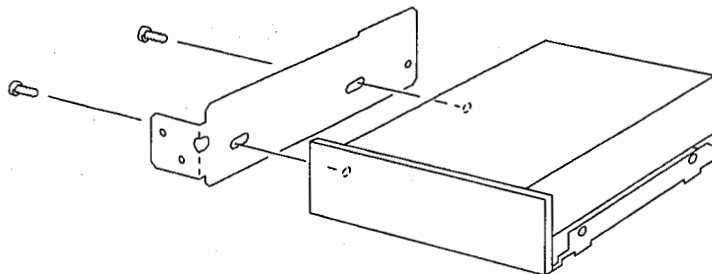

7. Install the floppy disk drive in the top drive bay and tighten the screws. Make sure the disk drive lines up with the opening in the computer cover.

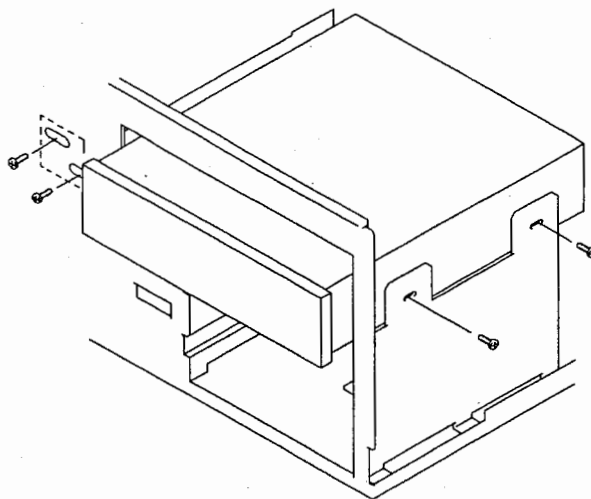

8. Refer to the floppy disk drive documentation to find pin 1 of the floppy disk drive connector.
9. If you are installing a 5.25-inch floppy disk drive, remove the 3.5-inch floppy disk drive adapter from the floppy disk drive controller cable.

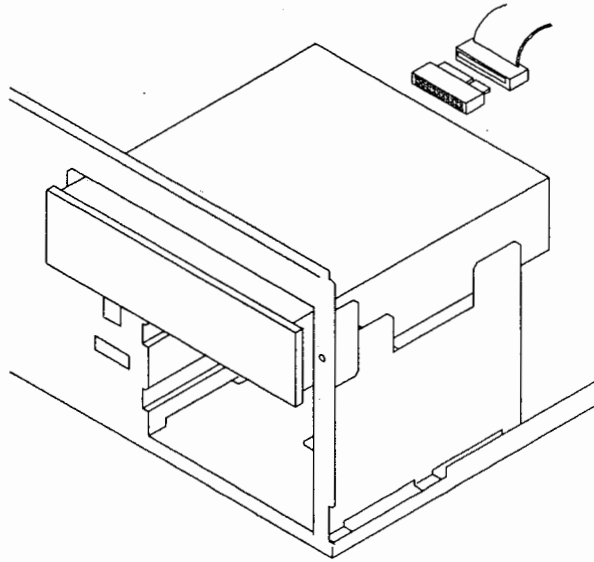

10. With the striped edge of the controller cable toward pin 1 of the floppy disk drive connector, attach the controller cable to the drive.

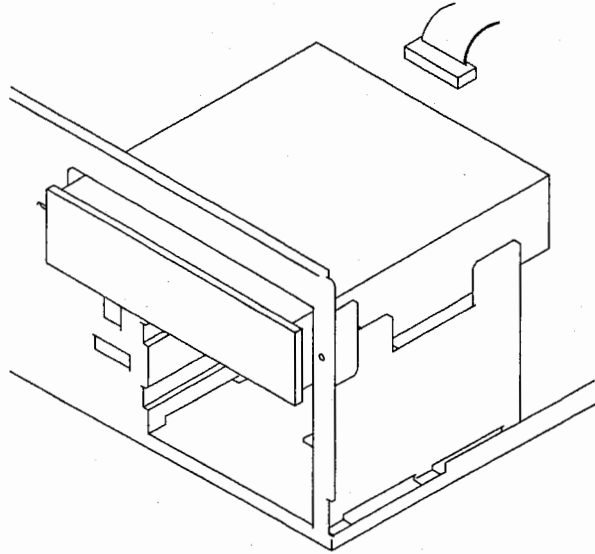

11. Attach the power cable to the drive. If the drive came with a shipping insert, remove it.

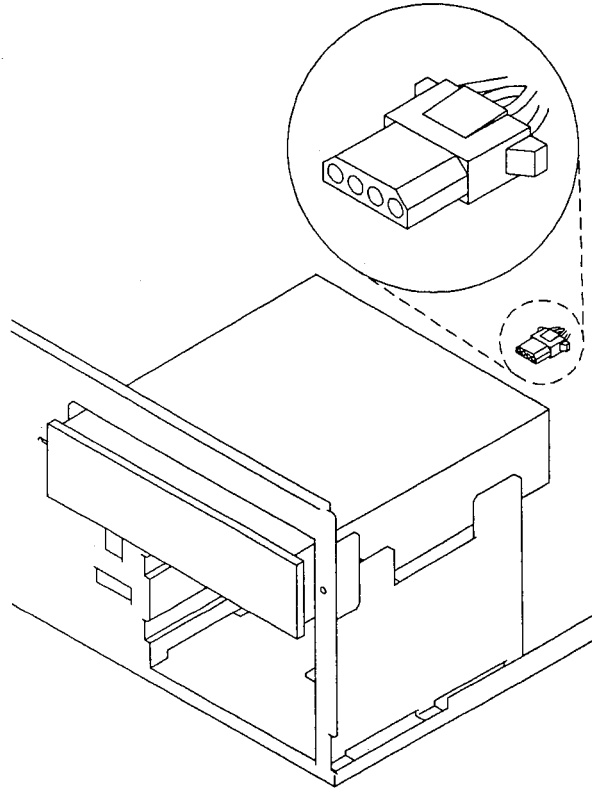

12. Replace the cover as described in the “Replacing the Cover” section later in this chapter.
13. Select *Disk Drives* from the Setup program menu to change the *Floppy 1 Type* field so the computer recognizes the new drive. Refer to the Setup chapter for more information.

## Hard Disk Drive

To install a hard disk drive in the bottom drive bay:

1. Make sure the hard disk drive is compatible with your computer. Contact your service center if necessary.
2. Remove the cover as described earlier.
3. Remove the bracket covering the bottom drive bay.

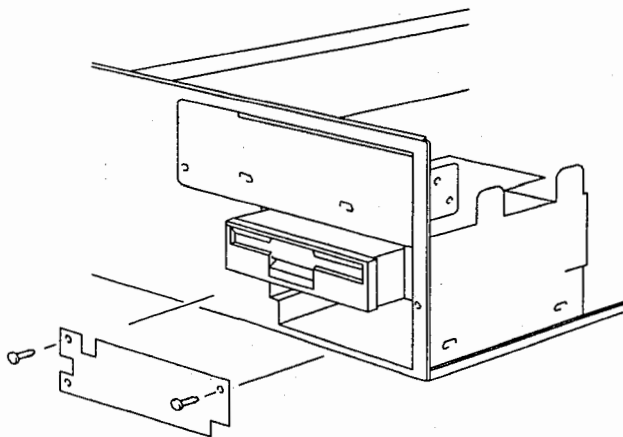



---

**Notice:** Observe static precautions.

---

4. Remove the hard disk drive from its protective packaging.
5. Attach the drive guide (if not already attached) to the hard disk drive.

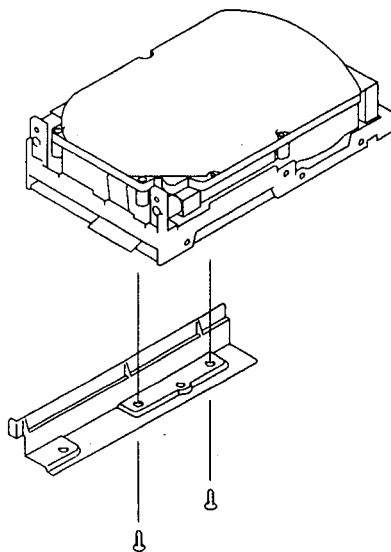

6. Carefully slide the hard drive assembly into the bottom drive bay and install the mounting screws.

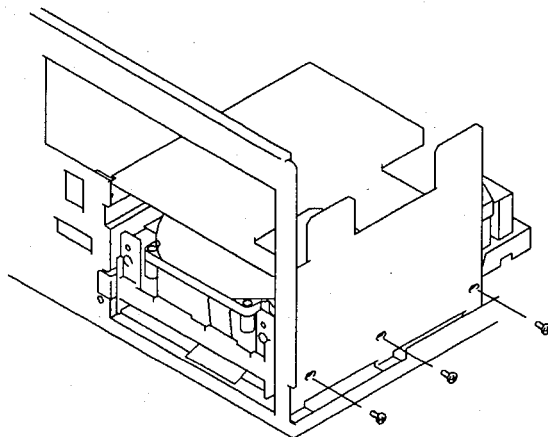

7. Reinstall the bracket.
8. With the striped edge of the controller cable facing the back of the computer, attach the controller cable to the hard disk drive connector (P118) on the system board.

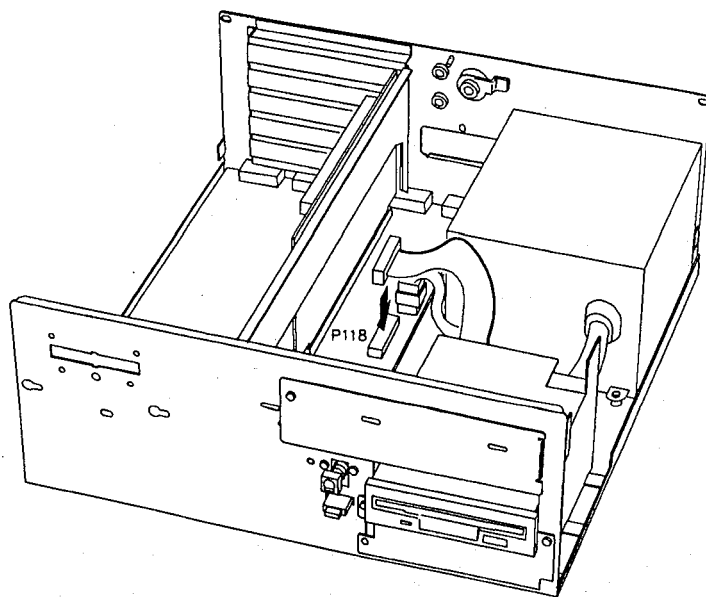

9. Refer to the hard disk drive documentation to find pin 1 of the hard disk drive connector.
10. With the striped edge of the controller cable toward pin 1 of the hard disk drive connector, attach the controller cable to the drive.

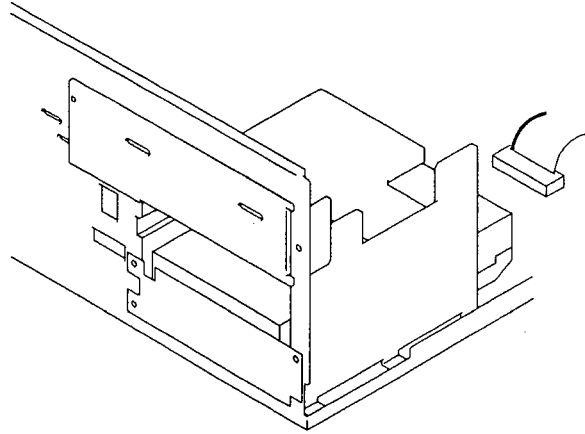

11. Attach the power cable to the hard disk drive.

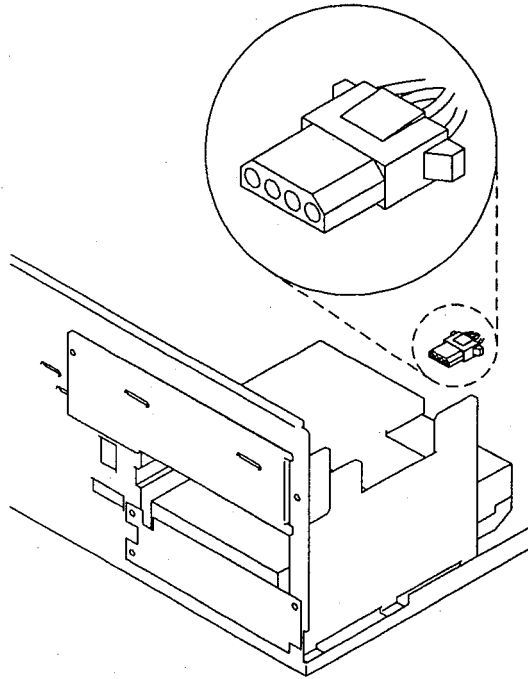

12. Replace the cover as described in the "Replacing the Cover" section later in this chapter.
13. Select *Disk Drives* from the Setup program to change the *Hard Disk 0 Type* field so the computer recognizes the new drive. Refer to the Setup chapter for more information.

## Circuit Cards

Optional circuit cards are installed on the backplane board inside your computer. The backplane board supports any XT- or AT-compatible circuit cards.

The backplane board contains five expansion slots, labeled P301 through P305. Refer to the following table and your circuit card documentation for card location limitations and specific requirements.

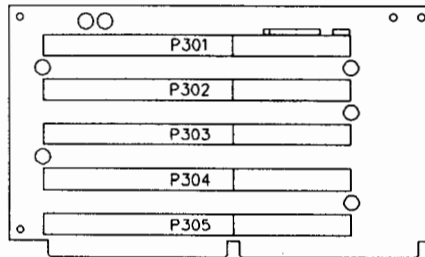

EXPANSION SLOT	CIRCUIT CARD SIZE	
	FULL LENGTH	HALF LENGTH OR TWO-THIRDS LENGTH
P301	Yes	Yes
P302	Yes	Yes
P303	Yes	Yes
P304	Yes	Yes
P305	No	Yes

To install a circuit card:

1. Remove the cover as described earlier.
2. Select an expansion slot. Remove the screw that holds the slot cover in place. Save the screw for later use.
3. Remove the slot cover from the expansion slot. Save the slot cover in case you ever remove the circuit card.

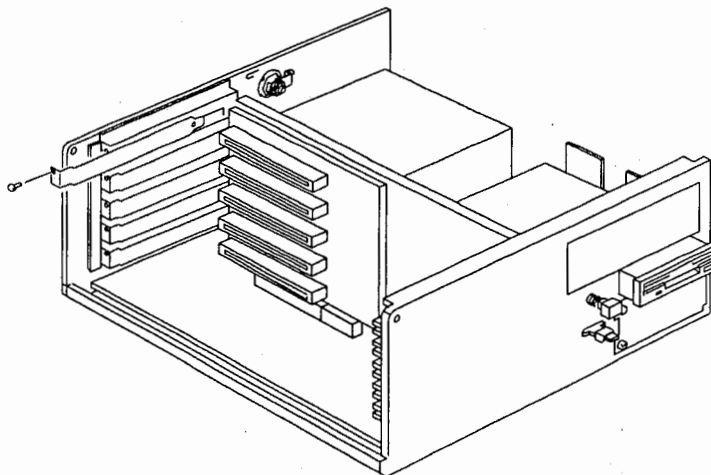

---

**Notice:** Observe static precautions.

---

4. Take the circuit card out of its protective packaging.
5. Set any necessary switches or jumpers on the circuit card as described in the circuit card documentation.

**Note:** Some circuit card manufacturers require you to set an interrupt request (IRQ) or a DMA request (DRQ) jumper on the circuit card. When setting jumpers, do not use the same IRQ or DRQ settings used by the computer. Refer to the Specifications for information on IRQ and DRQ settings used by this computer.

6. Position the circuit card with its connector toward the backplane board.
7. If you are installing a full-length card, slide the card into the card guide. If you are installing a half-length card, the card guide will not be used.

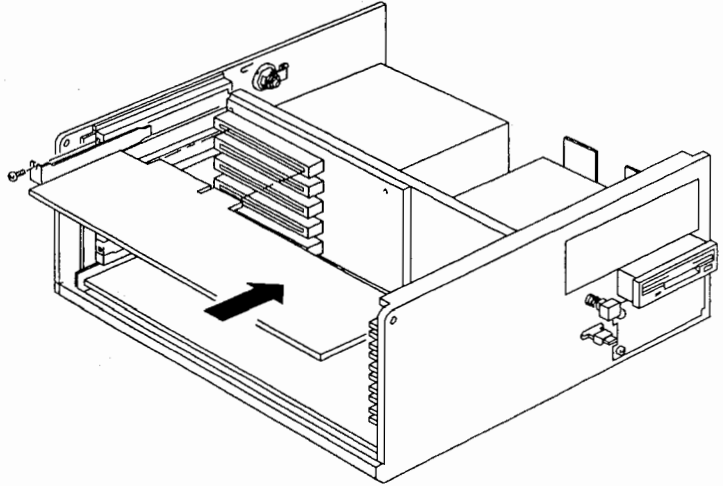

8. Press the card into the backplane board edge connector until the card stops.
9. Secure the circuit card to the computer cabinet with the screw saved in step 2.
10. Replace the cover as described in the "Replacing the Cover" section later in this chapter.
11. If you added an I/O card, change the Setup program as described in the Setup chapter.

## Replacing the Cover

To replace the cover:

1. Make sure all cables are properly routed and connected.
2. Facing the front of the computer, place the rear of the cover over the front of the computer.

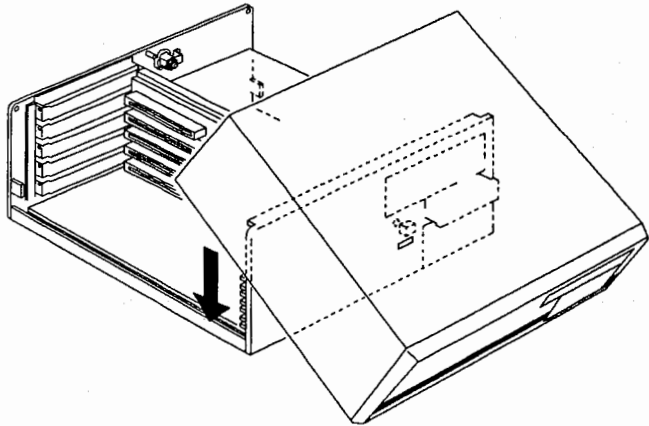



3. Carefully slide the cover onto the chassis. Be sure the tabs on each side of the chassis are lined up with the cover.

**Notice:** When replacing the cover, align the hard disk drive LED indicator and the on/off switch with the holes in the front bezel.

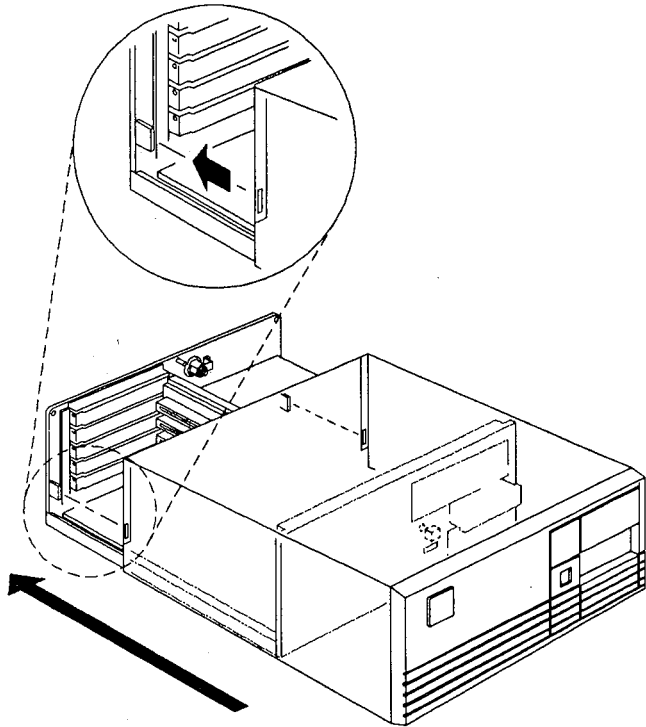

4. Replace the thumbscrews.
5. Lock the cover.
6. Connect the keyboard cable to the computer.
7. Connect the video monitor and peripherals to the computer.
8. Plug the computer's power cord into an AC outlet.

## Computer Stand

To assure proper air flow through the air vents, use a stand when setting your computer on its side. When using the computer stand, rotate the computer's logo so that it is in an upright position.

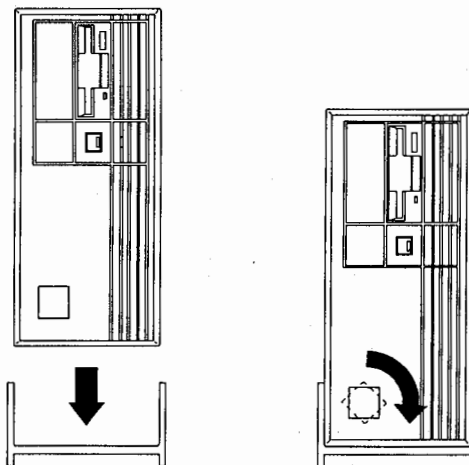



# Tests and Error Messages

---

---

## Contents

---

Check This First . . . . .	.A-2
Power-Up Tests . . . . .	.A-6
Using the Test Command . . . . .	.A-7
Disk Read Test . . . . .	.A-8
Keyboard Test . . . . .	.A-9
Base Memory Test . . . . .	.A-9
Extended Memory Test . . . . .	.A-9
Power-Up Test . . . . .	.A-9
Error Messages . . . . .	A-10

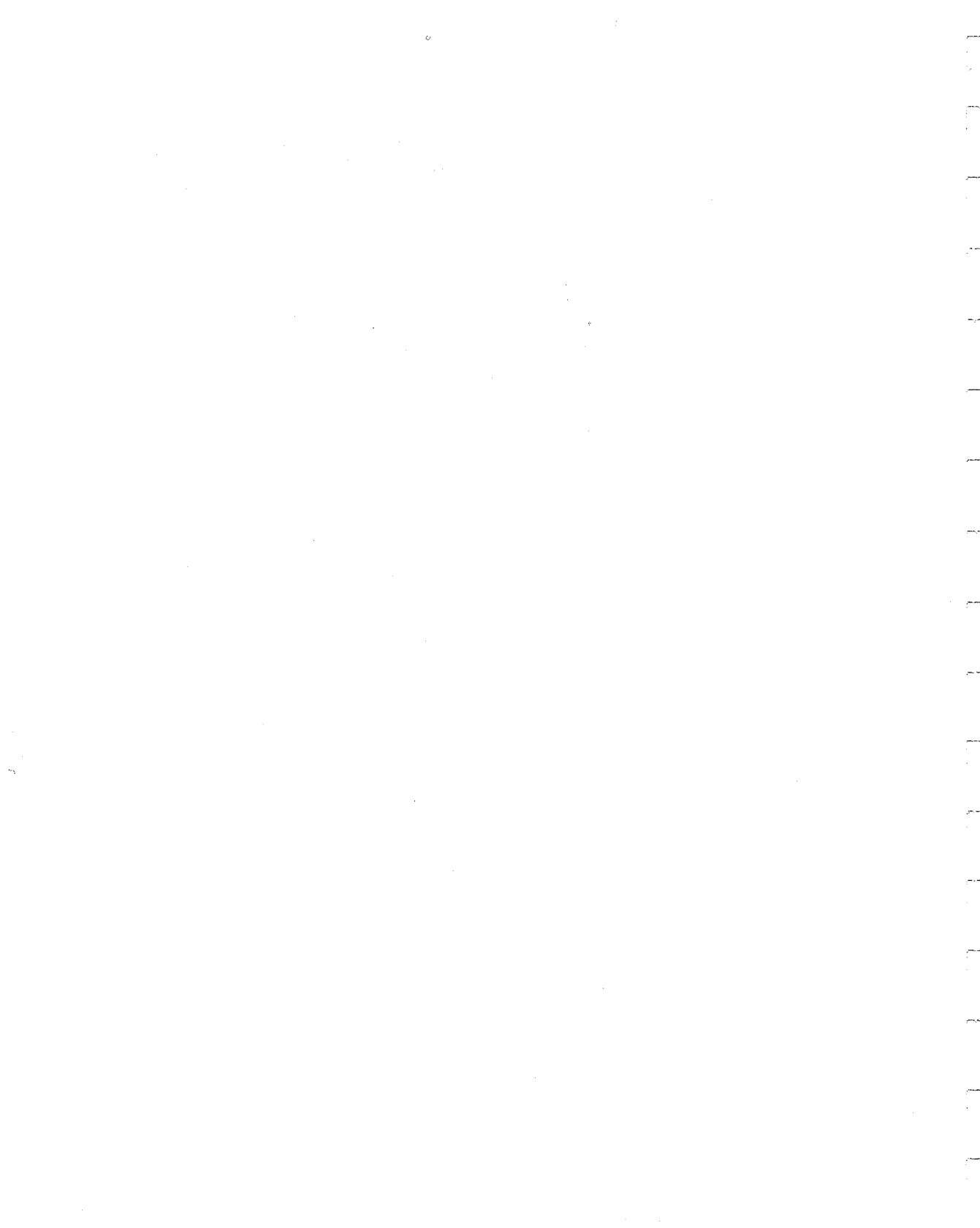

---

---

The Monitor program reports test and error messages on the video display. An error message can occur whenever the computer fails to function properly.

This appendix lists suggestions for correcting problems you may have with your computer. There are several ways to identify and solve problems:

- Use the "Check This First" section of this appendix for common problems and easy solutions.
- If an error message is displayed, refer to the table at the end of this appendix. The Monitor program can display one or more of these messages whenever the computer fails to function properly. Refer to The Monitor Program appendix for more information on the Monitor program.
- There are several tests that you can run from the keyboard to verify the performance of various parts of the computer. These tests are part of the Monitor program and are explained in this appendix.
- An optional disk-based diagnostics package can be purchased from your sales representative. This package includes comprehensive tests and an instruction manual.

## Check This First

Some of the items in this section require you to remove your computer's cover. Refer to the Hardware Upgrades chapter to remove the cover.



---

**Caution:** Hazardous voltages are present inside the computer when it is connected to the AC supply, even when the power switch on the computer is set to OFF. These voltages could cause personal injury. To avoid injury during service, maintenance, or adding enhancements, disconnect the power cord from the AC outlet and disconnect all peripherals from the computer before removing the computer cover.

---

Refer to the following list to find the problem the computer is experiencing, then check the possible causes in order. Contact your service representative if you cannot correct the problem.

1. Nothing happens when you turn on the computer; the power LED does not light and the power supply fan does not turn.
  - Verify that the power switch is on. If the computer is connected to a switched power strip, make sure the switch is on.
  - Verify that the power cords are connected to a working AC outlet. (Use a lamp to make sure there is power at the outlet.)
  - Check the computer power cord for damage. If necessary, replace it with a cord of the same type and rating.

If these checks do not solve the problem, remove the computer cover according to the instructions in the Hardware Upgrades chapter.

- Check to see if the diagnostic LEDs on the system board light up and then turn off in sequence as each circuit passes its test. The RDY LED remains lit until the operating system is read into computer memory from a disk.

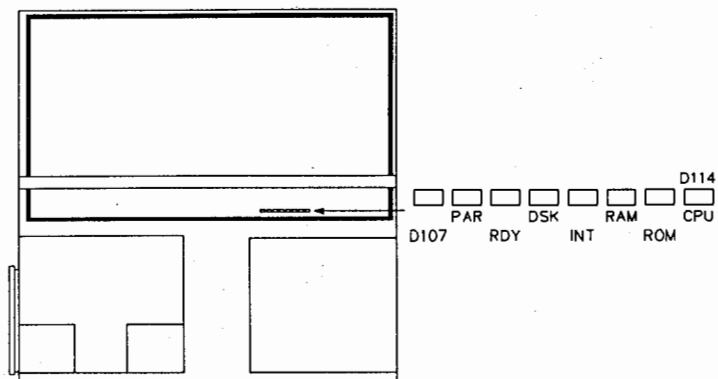



- Verify that the power supply cable is firmly connected to the system board.

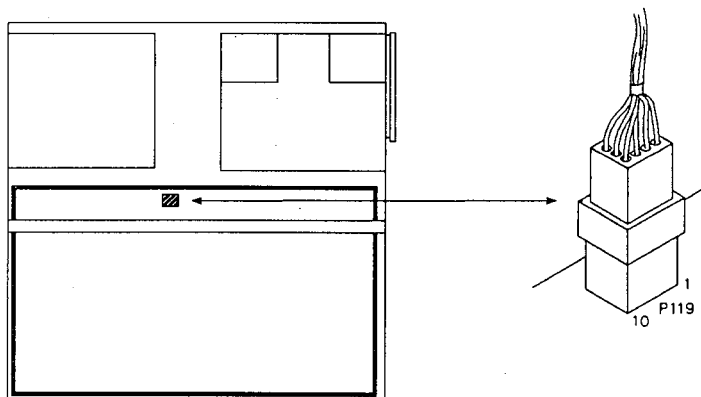

2. Upon power up or reset, the computer does not boot automatically.
  - Verify that the computer is configured to boot from the drive with the operating system installed. Refer to the Setup chapter for information.
  - If the computer is attempting to boot from the floppy drive, make sure the floppy disk is correctly inserted.
3. The computer resets to the power-up point or the disk keeps rebooting.
  - Check the power cord connection.
  - Boot from a different floppy disk. Your disk may be defective.
  - Check the cables leading to the floppy and/or hard disk drive. Make sure the cables are securely attached and undamaged.

4. There is no display or a poor display on the video monitor.
  - Make sure the monitor is connected to an AC outlet and that the power switch is turned on.
  - Verify that the monitor is properly connected to the computer and that the connection between the monitor and the computer is secure.
  - Adjust the brightness and contrast controls on the monitor.
5. The computer powers up, automatically boots or enters the Monitor program, but nothing happens when you press the keyboard keys.
  - Make sure the keyboard is plugged into the computer.
  - Check the keyboard cable for damage.
  - Enter your password. If that works, your password is set for the *No-Prompt* mode.

## Power-Up Tests

When you turn on power or reset your computer, it runs through a series of self-tests that check various circuits. These tests are part of the computer's Monitor program. The LED indicators on the system board, drives, and keyboard LEDs light up during the tests. They take just a few seconds to complete.

In the unlikely event the computer fails a test, it may beep and attempt to display an error message on the video monitor. Some of the more common power-up error messages are listed in the table near the end of this appendix.

## Using the Test Command

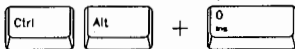

Your computer contains a built-in test program that you can use to detect hardware problems. To access these tests, press the CTRL-ALT-INS key combination.

Enter the password (if one is set).

When the Monitor prompt appears, type TEST then press ENTER.

```
MFM-300 Monitor, Version x.xx
Memory Size: xxxK + xxxK + xxK Cache
Enter "?" for help.
->TEST
```

The screen displays:

CHOOSE ONE OF THE FOLLOWING:

1. DISK READ TEST
2. KEYBOARD TEST
3. BASE MEMORY TEST
4. EXTENDED MEMORY TEST
5. POWER-UP TEST
6. EXIT

ENTER YOUR CHOICE:

Enter a number (1 through 5) to select a test. The test you select runs until an error is detected or you press ESC.

When an error is detected, the test stops and displays a message on the screen. Write this message down. If the computer needs to be serviced, this error message could help the service technician find the trouble quickly.

Refer to "Error Messages" at the end of this appendix for more information.

## Disk Read Test

If you see repeated disk error messages on your screen, run the Disk Read Test. This test checks the boot track of the last disk you booted from. To test a different drive, boot from a disk in that drive and then run the test.

A test failure can occur if:

- The boot track on the disk is corrupted.
- The memory containing the boot information is defective.
- The disk drive is defective.
- The drive controller is defective.

**Hard Disk Drive** — Back up the hard disk before you run this test.

If the test is successful, the hard disk drive LED indicator lights and the computer displays the test count on the screen.

If the hard disk drive test fails, you may need to “prep” and format the hard disk. Refer to the operating system documentation for hard disk preparation information. If the test fails again, have your computer serviced.

**Note:** Prepping or formatting the hard disk destroys all data on it. Back up the hard disk before prepping or formatting it.

**Floppy Disk Drive** — Place a formatted blank disk in the drive and run the test. Do not use a valuable disk to run the test; the data on it could be destroyed.

If the floppy disk drive test fails, place another formatted, blank disk in the drive and run the test again. If the test passes, your original test disk was defective. If the test fails again, have your computer serviced.

---

## Keyboard Test

The Keyboard Test checks the keyboard controller. When you press a key, the keyboard test fills the screen with the key character and displays the keycode in the upper right part of the screen.

If no screen display occurs when you press a key, have the computer and keyboard serviced.

## Base Memory Test

Use the Base Memory Test to verify that the computer's first 1M of RAM is functioning properly. As the test runs, the computer beeps and the screen displays:

SYSTEM AND VIDEO MEMORY TEST

The memory range being tested is displayed in the upper right corner of the screen.

## Extended Memory Test

Use the Extended Memory Test to verify that the computer's RAM above 1M is functioning. This extensive test takes 5 to 10 minutes to run.

## Power-Up Test

When you select the Power-Up Test, the computer performs the self-tests that are run each time you turn the computer on or reset it.

## Error Messages



Whenever an error message appears on the screen, press the ESC key. If you do not see the Monitor prompt or the Setup screen, or if a different error message appears, use the CTRL-ALT-INS key combination to enter the Monitor program. If the Monitor prompt still does not appear, turn your computer off, wait a short time, and turn it back on. If the error message appears again, contact your service representative for assistance.

The following table lists the error messages in alphabetical order and notes which problems are user-correctable. If the error message on your screen is not included in this table, check your software documentation.



**Caution:** Hazardous voltages are present inside the computer. To prevent electrical shock and personal injury, do not attempt to service this computer yourself – except as described in the table notes.

MESSAGE	USER- CORRECTABLE PROBLEM
DISK ERROR: Bad disk controller!	See Note 1
DISK ERROR: CRC error!	See Note 2
DISK ERROR: Disk not bootable!	See Note 3
DISK ERROR: DMA overrun!	No
DISK ERROR: Drive not ready!	See Note 4
DISK ERROR: Invalid address mark detected!	See Note 2
DISK ERROR: Invalid data read!	See Note 2
DISK ERROR: Sector not found!	See Note 5
DISK ERROR: Seek failure!	See Note 2
ERROR: Bad configuration information found in CMOS!	See Note 8
ERROR: Base memory size error: SETUP: XXXX ACTUAL: XXXX!	See Note 8
ERROR: Cache circuit card DATA RAM failure!	No
ERROR: Cache circuit card failure!	No
ERROR: Cache circuit card TAG RAM failure!	No
ERROR: CMOS Memory Failure!	No
ERROR: CPU failure!	No
ERROR: Divide by zero!	See Note 6
ERROR: Fatal RAM installation error!	No
ERROR: Invalid/No keyboard code received!	No
ERROR: Keyboard not responding or not connected!	See Note 10

MESSAGE	USER- CORRECTABLE PROBLEM
ERROR: Overflow!	See Note 6
ERROR: Please replace the back-up battery!	See Notes 7 and 8
ERROR: RAM failure! Address: xxxx:yyyy, Bit: n	See Note 11
ERROR: ROM checksum failure!	No
ERROR: Timer interrupt failure!	No
ERROR: Wild interrupt!	No
ERROR: Wild hardware interrupt!	No
FATAL: Internal Stack Failure, System Halted!	No
Non-maskable interrupt!	No
Non-system disk	See Note 9
Not a bootable partition	See Note 9
<b>NOTES:</b>	
<ol style="list-style-type: none"> <li>1. Check for the correct command entry.</li> <li>2. Often this message indicates that the data on the disk has been corrupted. Try using another copy of the disk.</li> <li>3. <b>Hard disk:</b> Make sure you specified a bootable drive. Specify the correct drive and reboot. <b>Floppy disk:</b> Make sure the disk is bootable. Try using another bootable disk.</li> <li>4. <b>Hard disk:</b> Contact your service representative. <b>Floppy disk:</b> Make sure the disk is properly inserted in the drive. Make sure you entered the boot command properly.</li> <li>5. The computer attempted to access an unformatted or damaged disk. <b>Hard disk:</b> Make sure you entered the boot command correctly. <b>Floppy disk:</b> Refer to your software documentation and copy any readable files to a good disk and reformat the faulty disk. If bad sectors are reported during formatting, discard the disk.</li> <li>6. The power-up self-tests failed or a software failure occurred. This message can appear if the computer is turned off and then back on very quickly. Turn the computer off, wait 15 seconds and turn it back on. Unless this message occurs during powerup, the problem is with the software. Try another copy of the software or contact the software manufacturer.</li> <li>7. Press ESC and verify the Setup program information. If the message is repeated, the backup battery must be replaced.</li> <li>8. Press ESC and re-enter the Setup program information. Be sure to save the information before you exit the Setup program.</li> <li>9. <b>Hard disk:</b> You tried to boot from a drive that does not have an operating system on it. Transfer the operating system to the drive, or try another drive and reboot. <b>Floppy disk:</b> You tried to boot from a disk that does not contain the operating system. Try booting from a disk that contains the operating system.</li> <li>10. Make sure the keyboard cable is fully inserted into the keyboard connector.</li> <li>11. Check the system board to make sure that a SIMM has not come out of its socket.</li> </ol>	



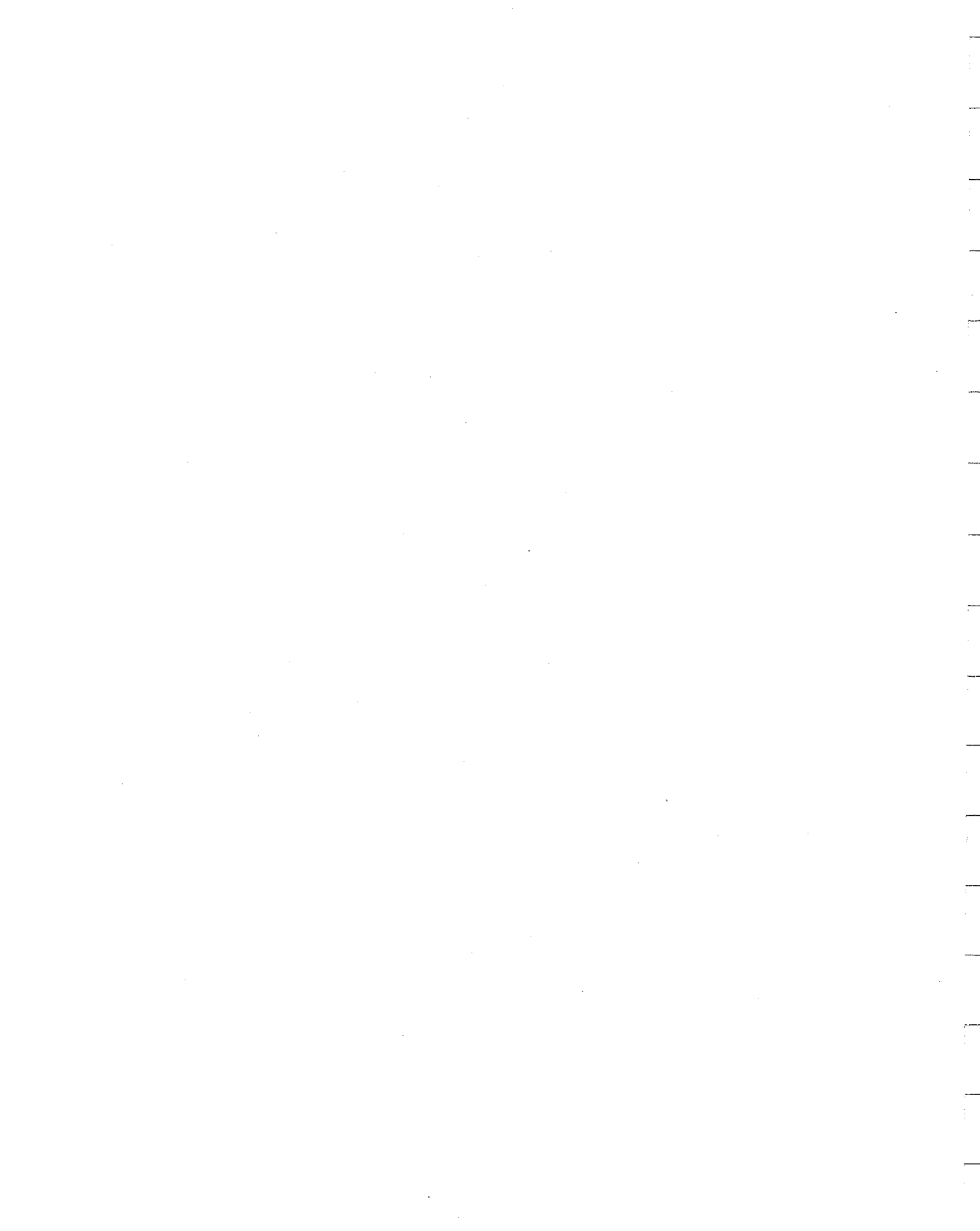

# The Monitor Program

---

---

## Contents

---

Using the Boot Command . . . . .	.B-3
Using the Video Command . . . . .	.B-4
Using the Color Bar Command . . . . .	.B-6
Using the Debugger Commands . . . . .	.B-7

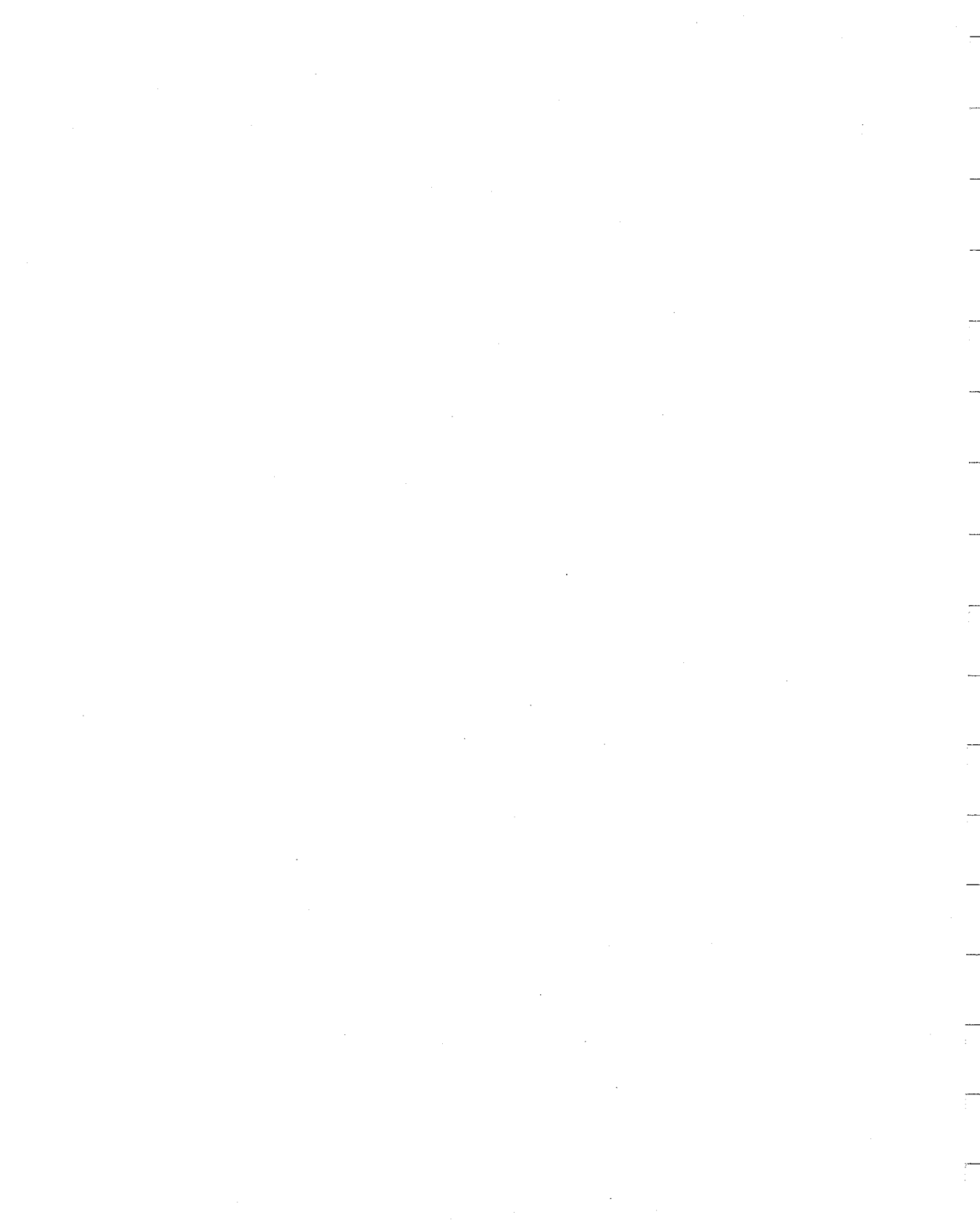

---

---

This appendix explains some additional functions of your computer's built-in MFM-300 (Multi-Function Monitor) program stored in ROM. These additional functions are:

- Boot commands
- Video commands
- Debugger commands.



Access the Monitor program with the CTRL-ALT-INS key combination. The screen displays a message similar to:

```
MFM-300 Monitor, Version x.xx  
Memory Size: xxxK + xxxxK + xxK Cache  
Enter "?" for help.  
->?
```

The prompt (->\_) indicates that the computer is under Monitor program control, and that it is ready to accept a Monitor command. If you enter a question mark (?), the Monitor program displays a command summary.

You can enter any of the commands listed in the MFM-300 command summary. Use the syntax shown, and then press ENTER to execute the command. The command syntax specifies:

- Optional entries in brackets [option].
- Choices of entries in braces {choice 1 | choice 2}.
- Required variables in angle braces <variable>.

If you use the syntax incorrectly, the computer reports that you entered an invalid command.

- MFM-300 Command Summary -		
<u>CMD:</u>	<u>Explanation</u>	<u>Syntax</u>
?:	Help	?
B:	Boot from disk	B [{F W}][{0 1 2 3}][:<partition>]
C:	Color bar	C
D:	Display memory	D [<range>]
E:	Examine memory	E <addr>
F:	Fill memory	F <range>,{<byte> "<string>}...
G:	Execute (Go)	G [=<addr>][,<breakpoint>]...
H:	Hex math	H <number1>,<number2>
I:	Input from port	I <port>
M:	Move memory block	M <range>,<dest>
O:	Output to port	O <port>,<value>
R:	Examine Registers	R [<register>]
S:	Search memory	S <range>,{<byte> "<string>}...
T:	Trace program	T [<count>]
U:	Unassemble program	U [<range>]
V:	Set Video/Scroll	V [M<mode>][S<scroll>]
	Where <range> is:	<addr>{,<addr> L<length>}
TEST:	Extended diagnostics	TEST
SETUP:	Define hardware Setup	SETUP
->_		

---

## Using the Boot Command

The boot command instructs the computer to load the operating system into memory from either the hard disk or a floppy disk.

To use the boot command:

1. Enter BFO to boot from floppy disk drive A

or

Enter BW0 to boot from the hard disk drive.

2. If you have partitioned the hard disk, you can specify the boot partition in the command. Enter BW0 followed by a colon and the partition number (1 through 4).

BW0: {1|2|3|4|}

3. Press ENTER. The computer loads the operating system from the specified partition.

## Using the Video Command

Use the video command to program any of several different video modes. The video mode determines the number of dots (pixels) displayed on the screen. The dot resolution determines the sharpness, character definition, number of lines, and number of colors in the display. Each mode offers a different display resolution and color scheme.

Software programs can change the resolution to provide different display characteristics. The following table lists the video modes that this computer supports.

To use the video command, type VM and the video mode number (and letter) from the following table, then press ENTER.

### *Video Modes*

VIDEO MODE	COLORS	TEXT	RESOLUTION GRAPHICS
<b>Alphanumeric Modes</b>			
0,1 (color)	16	40 x 25	CGA — 320 x 200
	16 of 64		EGA — 320 x 350
	16 of 256K		VGA — 360 x 400
2,3 (color)	16	80 x 25	CGA — 640 x 200
	16 of 64		EGA — 640 x 350
	16 of 256K		VGA — 720 x 400
7 (monochrome)	2	80 x 25	MDA — 720 x 350
	2		EGA — 720 x 350
	2		VGA — 720 x 400
1C (color)	16	132 x 25	VGA — 924 x 400
1D (color)	16	132 x 43	VGA — 924 x 386

*continued...*

VIDEO MODE	COLORS	TEXT	RESOLUTION GRAPHICS
<b>Graphics Modes</b>			
4 (color)	4 of 256K		VGA - 320 x 200
5 (color)	4 of 256K		VGA - 320 x 200
6 (color)	2 of 4		CGA - 640 x 200
	2 of 64		EGA - 640 x 200
	2 of 256K		VGA - 640 x 200
D (color)	16 of 64		EGA - 320 x 200
	16 of 256K		VGA - 320 x 200
E (color)	16 of 64		EGA - 640 x 200
	16 of 256K		VGA - 640 x 200
F (monochrome)	16		EGA - 640 x 350
	16		VGA - 640 x 350
10 (color)	6 of 64		EGA - 640 x 350
	16 of 256K		VGA - 640 x 350
11 (color)	2 of 256K		EGA - 640 x 480
	2 of 256K		VGA - 640 x 480
12 (color)	16 of 256K		VGA - 640 x 480
13 (color)	256 of 256K		VGA - 320 x 200



## Using the Color Bar Command

The color bar command displays 16 color bars on color video monitors, and three to 16 shades on monochrome monitors. Use the color bar and the video monitor's brightness and contrast controls to adjust the video monitor.

To use the color bar command, type C, then press ENTER.

## Using the Debugger Commands

The MFM-300 command summary contains a set of assembly language debugger commands that programmers can use to verify routines, examine memory, examine registers, and debug assembler programs. The following table lists these commands.

**Notice:** Do not use the debugger commands if you do not understand assembly level programming techniques.

To use the debugger commands, type the command using the syntax in the following table, then press ENTER.

COMMAND	SYNTAX	DESCRIPTION
Display memory	D <address>	Displays contents of 128 bytes of memory beginning at specified address.
	D <address>,L<bytes>	Displays contents of specified number of bytes of memory beginning at specified address.
	D <range>	Displays contents of specified block of memory.
Examine memory	E <address>	Displays contents of specified memory location and allows modifications.
Fill memory	F <range>,<data byte>	Enters specified data byte into each memory block.
	F <range>," <string> "	Enters specified ASCII string into specified memory block.
Execute (Go)	G = <address>	Begins execution of program at specified address.
	G = <address>,<breakpoint>	Begins execution of program at specified address and halts at breakpoint.
Hex math	H <number1>,<number2>	Displays the sum and the difference of the specified hexadecimal numbers.
	H <register1>,<register2>	Displays the sum and difference of the hexadecimal numbers contained in the specified registers.

*continued...*

COMMAND	SYNTAX	DESCRIPTION
Input from port	I<port address>	Displays contents of specified port.
Move memory block	M<range>,<destination>	Moves specified memory block to another specified memory block.
Output to port	O<port address>,<data>	Writes specified data to specified port address.
Examine Registers	R<register name>	Displays contents of specified CPU register and allows modification.
Search memory	S<address>L<bytes>,<data>	Searches specified memory block for specified data byte and displays address(es) where data was found.
	S<address>L<bytes>,"<string>"	Searches specified memory block for specified ASCII string and displays address(es) where string was found.
Trace program	T<count>	Executes specified number of lines of an assembled program in single-step mode.
Unassemble program	U<range>	Displays assembler mnemonics and hex coding for specified memory block.

Appendix C  
**Backup Battery**

---

---

**Contents**

---

Battery Life . . . . .	.C-1
Replacing . . . . .	.C-2

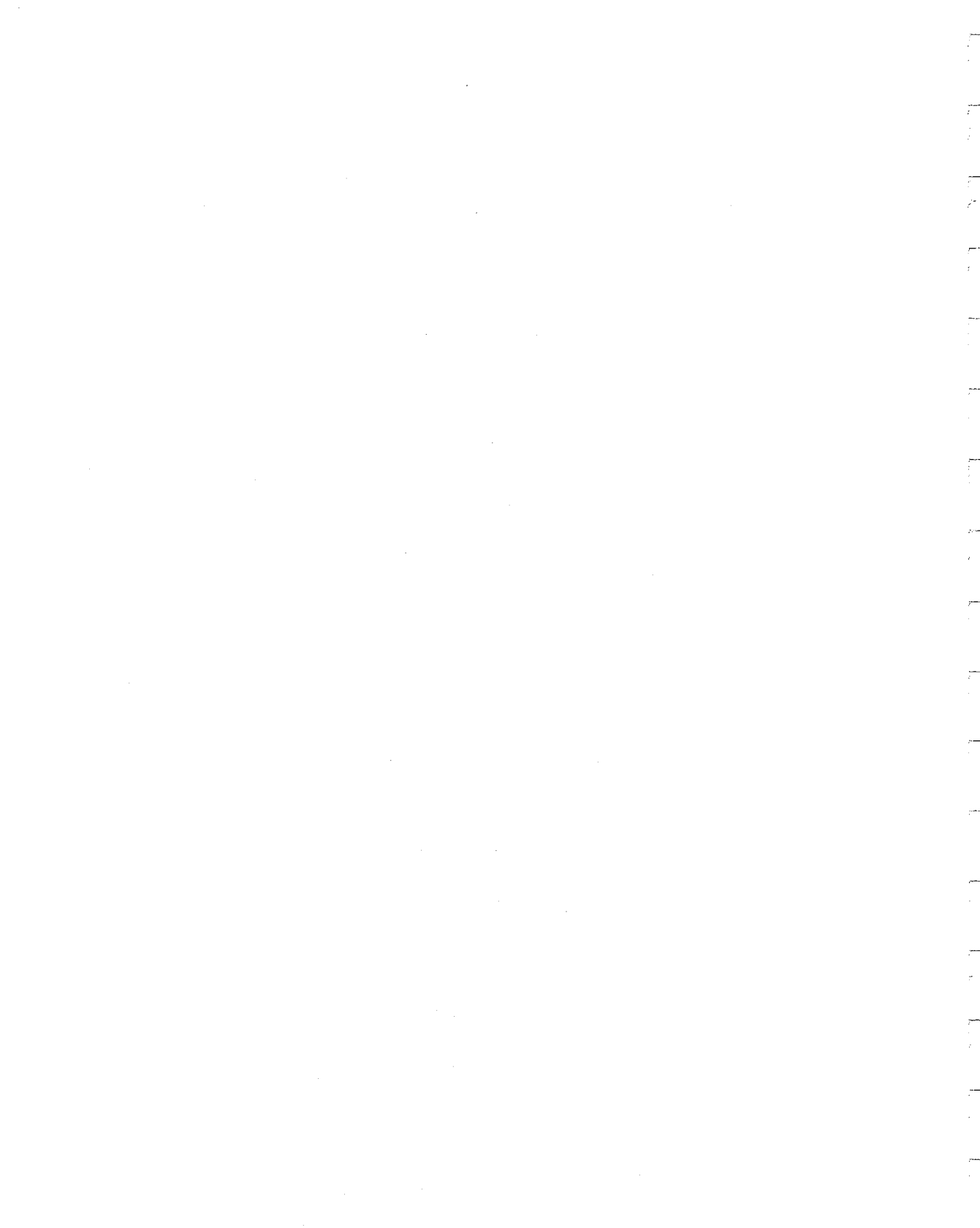

---

---

The lithium backup battery in your computer maintains the time, date, and configuration information when AC power is not available.

## **Battery Life**

The lithium backup battery should last approximately three years (assuming a 40-hour work week). When the backup battery is low, the computer displays the message:

Please replace the back-up battery!

- Errors found! Please press <ESC> to continue -

## Replacing



**Warning:** Lithium batteries can be dangerous. Improper handling or installation of lithium batteries may result in an explosion that could cause serious personal injury to anyone standing nearby. Do **not** try to recharge lithium batteries, short the terminals together, open them, or dispose of them in the garbage or in a fire. Replace them only with an exact replacement. Dispose of lithium batteries by returning them to your dealer.

To replace the backup battery:

1. Remove the cover as described in the Hardware Upgrades chapter.
2. Locate the backup battery on the system board.
3. Insert a small flat-bladed screwdriver on the side of the battery socket and push outward on the tab to release the clamp.
4. Remove the clamp.

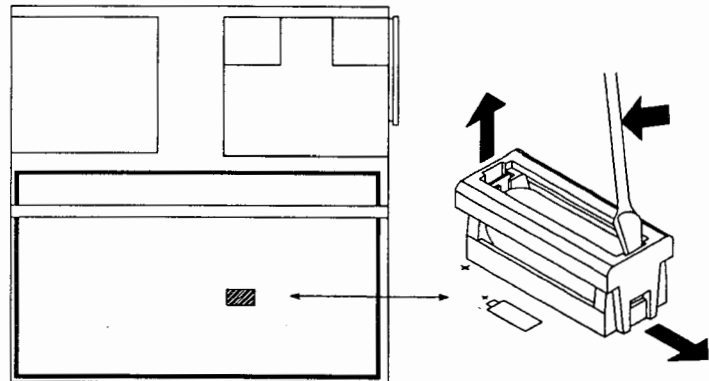

5. Remove the backup battery from its socket on the system board.

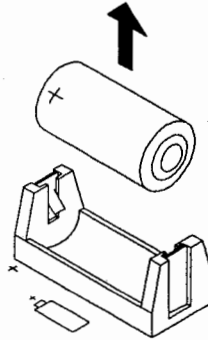

6. Align the positive (+) end of the new backup battery with the positive (+) end of the socket on the system board.



7. Install the new backup battery in the socket.
8. Install the clamp on the backup battery socket.

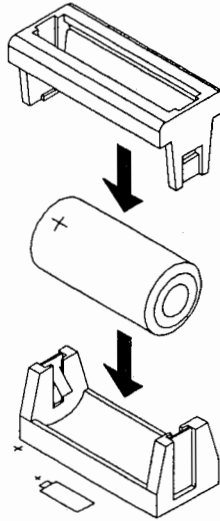

9. Replace the cover as described in the Hardware Upgrades chapter.
10. Return the old battery to your dealer for disposal.

# Specifications

---

---

## Contents

---

Power . . . . .	S-1
Processors . . . . .	S-2
Standard . . . . .	S-2
Optional . . . . .	S-2
Memory . . . . .	S-3
System Board . . . . .	S-3
Memory Map . . . . .	S-4
Input/Output Ports . . . . .	S-5
Mouse Port . . . . .	S-6
Audio . . . . .	S-6
Video . . . . .	S-7
Video Output Signals . . . . .	S-7
Video Monitor Compatibility . . . . .	S-7
Colors/Shades Displayed . . . . .	S-7
Monitor Interface . . . . .	S-8
VGA Features Connector . . . . .	S-9
Disk Drives . . . . .	S-10
Floppy Disk Drives . . . . .	S-10
Hard Disk Drives . . . . .	S-10
Keyboard . . . . .	S-11
Key Layout . . . . .	S-11
Features . . . . .	S-11

Backplane Board . . . . .	S-11
Hardware Interrupt Requests . . . . .	S-12
DMA Requests . . . . .	S-12
Cabinet . . . . .	S-13
Dimensions . . . . .	S-13
Weight . . . . .	S-13
Environmental . . . . .	S-13
Temperature . . . . .	S-13
Humidity . . . . .	S-13
Altitude . . . . .	S-13
System Board . . . . .	S-14
Configuration . . . . .	S-14
Diagnostic LEDs . . . . .	S-14
Connectors . . . . .	S-15

---

---

## Power

AC Input	90 to 132 VAC
	180 to 264 VAC
	50/60 Hz.
DC Output	+5 VDC, 14 A
	+12 VDC, 4 A
	-12 VDC, 500 mA.

### Power Supply Connector

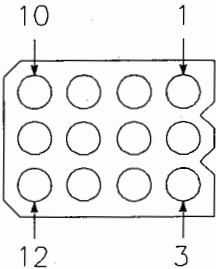
	PIN	SIGNAL
	1	Ground
	2	Ground
	3	Ground
	4	VCC (+5 VDC)
	5	VCC (+5 VDC)
	6	VCC (+5 VDC)
	7	+12 VDC
	8	Ground
	9	-12 VDC
	10	Power good
	11	Ground
	12	VCC (+5 VDC)

Output Rating	125 watts.
Backup Battery	+3.6 VDC. Lithium backup battery provides power to real-time clock and CMOS memory.

**Processors**Standard

---

Type                      80386SX 16-bit external, 32-bit internal microprocessor.  
Clock Speed              20 MHz system clock running at 0 (effective) wait states.

Optional

---

Type                      80387SX or compatible numeric coprocessor.  
Clock Speed              20 MHz.

## Memory

### System Board

---

RAM	<p>2M x 9 dynamic RAM standard, expandable to 26M by filling all banks with 4M x 9 SIMMs.</p> <p>2M x 9 DRAMs on system board. Installed memory can be split among base RAM, extended RAM, and EMS RAM.</p>
EMS	1024K available LIM 3.2, expandable to 25M.
Cache	<p>64K, organized as 32K x 16.</p> <p>Direct map.</p>
ROM	Socketed ROM contains firmware code which moves into a special area of memory (slushware RAM) at power up. Slushware increases the execution speed of the BIOS code.
EEPROM	2048-bit nonvolatile password and hardware configuration information storage.
CMOS RAM	128 bytes of battery backed-up CMOS RAM. Stores time, date, and hardware configuration information.

Memory Map

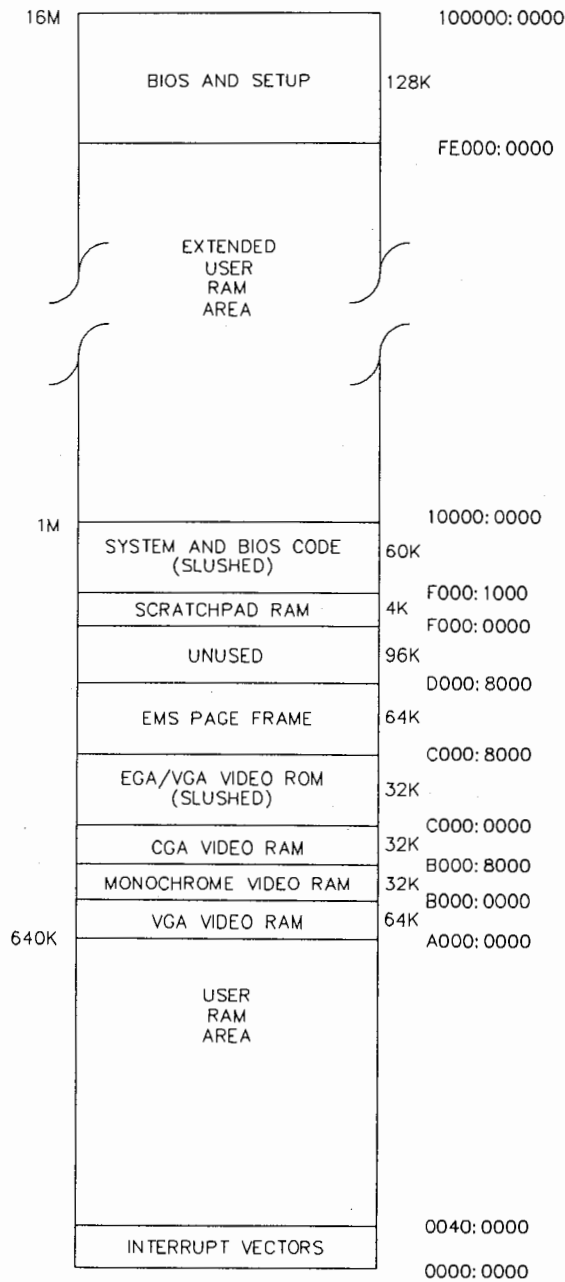

## Input/Output Ports

### Serial Port (male connector)

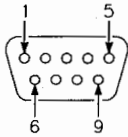

PIN	SIGNAL
1	Carrier Detect (CD)
2	Receive Data (RD)
3	Transmit Data (TD)
4	Data Terminal Ready (DTR)
5	Ground
6	Data Set Ready (DSR)
7	Request To Send (RTS)
8	Clear To Send (CTS)
9	Ring Indicate (RI)

### Parallel Port (female connector)

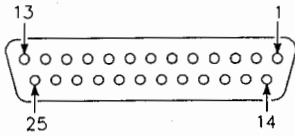

PIN	SIGNAL
1	Strobe
2 - 9	Data bits 0 - 7
10	Acknowledge
11	Busy
12	Page end
13	Select
14	Auto feed
15	Error
16	Initialize printer
17	Select input
18 - 25	Ground



## Mouse Port

Connector Interface connector provides 100% support for PS/2-compatible pointing device.

### *Mouse Port Connector*

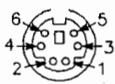
	PIN	SIGNAL
	1	Serial data
	2	Not connected
	3	Ground
	4	+5 VDC
	5	Clock
	6	Not connected

## Audio

One 8 $\Omega$ , 2-inch speaker.

---

## Video

**Compatibility** VGA-compatible video on the system board. Can support an add-on video card.

100% VGA register- and BIOS-level compatible; supports MDA, CGA, and EGA formats as a subset of VGA. Also supports extended VGA 640 x 480 line (132 column x 43 rows).

**Display Memory** 512K DRAM.

---

### Video Output Signals

Analog RGB signals, color and monochrome.

---

### Video Monitor Compatibility

Analog RGB color or monochrome monitors that operate at 31.49 kHz (VGA 480-line).

100% compatible with standard PC display modes (MDA, HGC, CGA, EGA, VGA).

---

### Colors/Shades Displayed

Depends on video display and mode:

Monochrome – 2 to 16 levels on gray scale.

Color – Up to 256 of 262,144 colors or shades.

## Monitor Interface

Video signals are 31.49 kHz analog RGB, 75Ω.

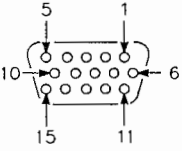
	PIN	SIGNAL
	1	Red video
	2	Green video
	3	Blue video
	4	No connection
	5	Ground
	6	Red ground
	7	Green ground
	8	Blue ground
	9	Ground
	10	Sync ground
	11	No connection
	12	No connection
	13	Horizontal sync
	14	Vertical sync
	15	No connection

VGA Features Connector

The VGA features connector allows communication between the VGA video and a compatible high-resolution video card.

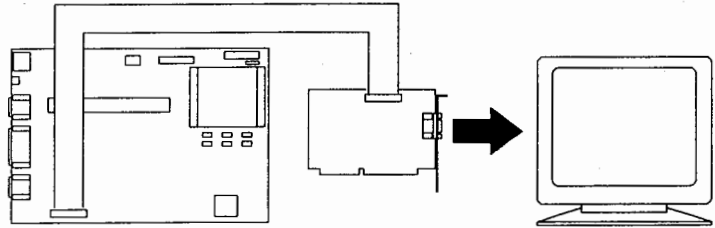

VGA Features Connector Pin Assignments

	PIN	FUNCTION	PIN	FUNCTION
	1	GND	14	Video pixel 6
	2	Video pixel 0	15	GND
	3	GND	16	Video pixel 7
	4	Video pixel 1	17	GND
	5	GND	18	Pclock
	6	Video pixel 2	19	GND
	7	Data EN	20	Blank
	8	Video pixel 3	21	GND
	9	Sync EN	22	H sync
	10	Video pixel 4	23	NC
	11	Pclock EN	24	V sync
	12	Video pixel 5	25	NC
	13	NC	26	NC

## Disk Drives

Supports a maximum of three internal disk drives. The drive chassis can accommodate two 3.5-inch drives and one 5.25-inch half-height drive.

### Floppy Disk Drives

---

Supports the following internal floppy disk drives:

3.5-inch 720K

3.5-inch 1.4M

5.25-inch 360K

5.25-inch 1.2M.

### Hard Disk Drives

---

Supports one of the following internal hard disk drives:

3.5-inch 80M, IDE controller

3.5-inch 200M, IDE controller.

## Keyboard

### Key Layout

101-key keyboard including alphanumeric, cursor control, numeric, and programmable function keys.

### Features

Key repetition, tactile keys.

### Keyboard Connector

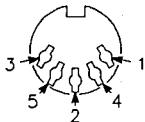
	PIN	SIGNAL
	1	Clock
	2	Data
	3	Reset
	4	Ground
	5	+5 volts

## Backplane Board

5-slot XT/AT-compatible expansion bus.

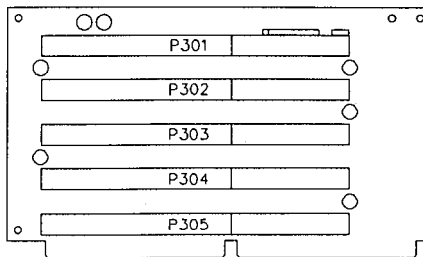

## Hardware Interrupt Requests

The following table shows the IRQ settings used by this computer.

### *Interrupt Requests*

TYPE	FUNCTION
IRQ0	Time-of-day timer
IRQ1	Keyboard
IRQ2	Slave controller input for IRQ8 – IRQ15
IRQ3 <sup>1</sup>	Serial port (COM2)
IRQ4 <sup>1</sup>	Serial port (COM1)
IRQ5 <sup>1</sup>	Parallel port (LPT2)
IRQ6	Floppy disk drive
IRQ7 <sup>1</sup>	Parallel port (LPT1)
IRQ8	Real-time clock
IRQ9	Redirect cascade
IRQ10	Available
IRQ11	Available
IRQ12 <sup>2</sup>	Mouse
IRQ13	Numeric coprocessor
IRQ14	Hard disk drive
IRQ15	Available

**NOTES**

1. Available if port is disabled.
2. Available if PS/2 mouse is disconnected before powering up the computer.

## DMA Requests

DMA request channel 2 (DRQ2) is used for the floppy disk drive. All other channels are available.

---

## Cabinet

### Dimensions

---

Width 14 inches (35.56 cm).

Depth 15 inches (38.1 cm).

Height 6 inches (15.24 cm).

### Weight

---

Computer ≈18 lbs. (8.2 kg) with one floppy drive and a hard drive.

## Environmental

### Temperature

---

Operating 41 to 95 degrees F (5 to 35 degrees C).

Non-operating 5 to 140 degrees F (-15 to 60 degrees C).

### Humidity

---

Operating 10% to 80% non-condensing.

Non-operating 10% to 80% non-condensing.

### Altitude

---

Operating -200 to 10,000 feet (-60 to 3,000 meters).

Non-operating -200 to 40,000 feet (-60 to 12,000 meters).



## System Board

### Configuration

The system board contains a four-position DIP switch that is configured as shown in the following table.

#### System Board Configuration Switch

PIN	FUNCTION
1	ON = Monitor program not accessible OFF = Monitor program accessible
2	ON = Asynchronous coprocessor (not supported) OFF = Synchronous coprocessor
3	ON = Hex check point LEDs OFF = Power-on diagnostic LEDs
4	Reserved

  

**NOTE**  
The default setting on all pins is OFF.

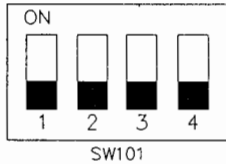

### Diagnostic LEDs

The system board contains seven diagnostic LEDs used for troubleshooting the computer.

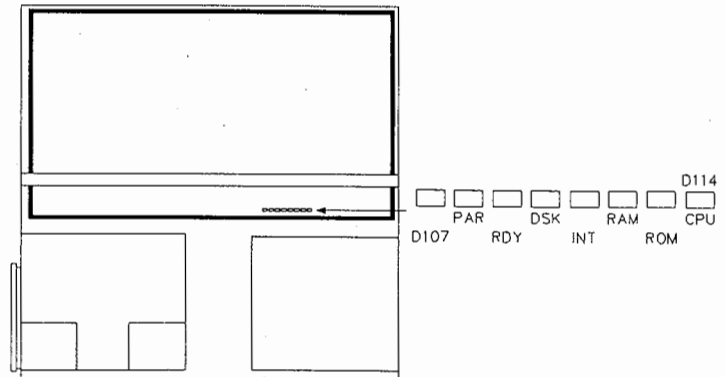

## Connectors

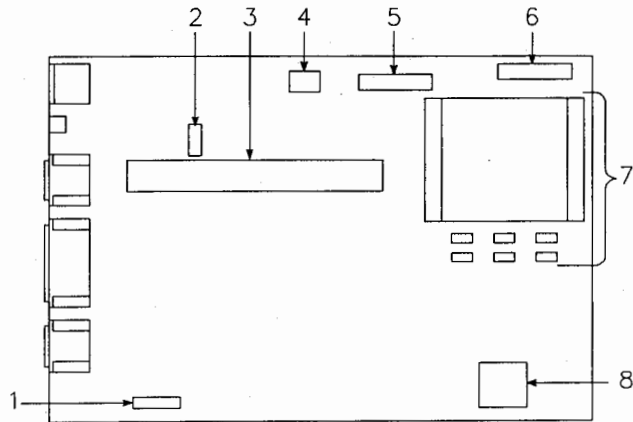
*System Board Connectors*

REFERENCE	DESCRIPTION
1	Feature connector
2	Serial board connector
3	Backplane board connector
4	Power connector
5	Hard disk drive interface
6	Floppy disk drive interface
7	Memory banks
8	Numeric coprocessor socket



# Glossary

---

- 8088** A type of microprocessor that can process 16 bits of data at a time, but communicates with 8-bit devices.
- 80286** A type of microprocessor that processes and communicates 16 bits of data at a time.
- 80386** A type of microprocessor that processes and communicates 32 bits of data at a time.
- 80386SL** A type of microprocessor that integrates an 80386SX microprocessor with memory and bus controllers. This microprocessor contains power management capabilities.
- 80386SX** A type of microprocessor that can process 32 bits of data at a time, but communicates with 16-bit devices.
- 80486** A type of microprocessor, with a built-in numeric coprocessor and cache memory, that processes and communicates 32 bits of data at a time.
- 80486SX** A type of processor, with built-in cache memory, that processes and communicates 32 bits of data at a time.

**A**

- AC** (Alternating Current) The type of current available in wall outlets. All computers must convert alternating current to direct current to operate. *See also* DC.
- AC adapter** The power supply for portable computers that converts AC to DC required by the computer. *See also* AC and DC.
- address** A label, name, or number that identifies a location in computer memory.
- ANSI** (American National Standards Institute) An organization that develops standards for computers.
- ASCII** (American Standard Code for Information Interchange) A standard number assigned to each of the alphanumeric characters and keyboard control code keys to enable the transfer of information between different types of computers and peripherals.
- assembly language** A programming language in which each program statement represents an instruction that the microprocessor executes.
- autoboot** The process of automatically loading the operating system. Your computer can be configured to autoboot when it is turned on.

---

**B**

- backup** A copy of data from computer memory or a disk to either a floppy disk or magnetic tape for safe-keeping.
- backup battery** The battery in your computer that maintains the real-time clock and the configuration information when the computer's power is removed.
- base memory** An area of memory between 0 and 640 kilobytes.
- battery pack** The main group of batteries used to power a portable computer.
- baud rate** The speed with which data is transmitted during serial communication. The computer's operating system and software program must be configured for the same baud rate as the communication device, such as a serial printer. *See also* bps.
- BIOS** (Basic Input Output System) A program stored in ROM (read-only memory) that controls the keyboard, disk drives, video monitor, and other devices.
- bit** Derived from **BI**nary **di**gi**T**, a bit is the smallest unit of information a computer handles. *See also* byte.
- boot** The process of loading the operating system.
- bps** (bits per second) The number of bits transferred in one second during serial communication, such as modem transmission.
- byte** A group of eight bits.

**C**

- cache memory** A very fast, limited portion of RAM set aside for temporary storage of data for direct access by the microprocessor.
- Centronics port** An industry standard parallel port. *See also* parallel port.
- CGA** (Color Graphics Adapter) A type of video display that provides medium-resolution text and graphics on color and monochrome monitors.
- CMOS** (Complimentary Metal-Oxide Semiconductor) A popular family of low-power integrated circuits used in computers. *See also* TTL.
- COM1 or COM2** The name you can assign a serial port to set or change its address. *See also* serial port.
- command** An instruction that directs the computer to perform a particular operation.
- coprocessor** *See* numeric coprocessor.
- CPU** (Central Processing Unit) *See* microprocessor.
- CRT** (Cathode-Ray Tube) The type of video display used in monitors for desktop computers.

**D**

- DC** (Direct Current) The type of current available in the rechargeable battery packs used in portable computers. *See also* AC.
- debugger command** An instruction built into the computer that is useful in finding "bugs" or problems in the computer's hardware and software.
- default** The setting your computer uses unless you instruct otherwise. For example, when powering up, the computer will boot from the default drive. Default settings can be changed using the Setup program.
- density** The capacity of information (bytes) that can be packed onto a storage device, such as a floppy disk.
- disk drive** A device that saves and recovers data on a hard or floppy disk. A floppy disk drive requires a floppy disk to be inserted; a hard disk drive may be fixed or removable (cartridge) and has a permanently encased hard disk.
- DOS** (Disk Operating System) *See* operating system.
- download** The process of transferring information from another computer or storage device to your computer. *See also* upload.



**E**

- EGA** (Enhanced Graphics Adapter) A type of video display that provides high-resolution text and graphics on TTL-monochrome, color, and enhanced color monitors.
- EEPROM** (Electrically Erasable Programmable Read-Only Memory) A type of memory chip that stores password and configuration information.
- EMS** (Expanded Memory Specification) A method of accessing memory beyond the 640K limit of DOS by exchanging data in and out of main memory at high speeds. Some software requires EMS to operate.
- EPROM** (Erasable Programmable Read-Only Memory) A type of memory chip that is usually used to store system BIOS code. This device is erasable with ultraviolet light.
- ESDI** (Enhanced Small Device Interface) A technology that enables your computer to communicate with the hard disk drive at very high speeds.
- expanded memory** *See EMS.*
- expansion slot** A connector inside desktop computers and expansion boxes that allows you to insert additional circuit cards.
- extended memory** The protected memory above 1M that is directly accessible by the microprocessor through certain utilities and operating systems. This memory is used in computers with 80286, 80386, and 80486 microprocessors.

**F**

- firmware** Programs permanently stored in your computer's ROM. *See also* ROM.
- flash EPROM** A type of memory chip that combines the electrical erase feature of an EEPROM with the density of an EPROM.
- floppy disk drive** *See* disk drive.
- format** The process used to organize a hard or floppy disk into sectors so it can accept data. Formatting destroys all previous data on the disk.

**H**

- hard disk drive** *See* disk drive.
- hard drive type** The number used by the Setup program that represents the physical description of your hard disk drive. You must change this number if you install a different type of hard disk drive.
- hardware** The physical parts of your computer, including the keyboard, monitor, disk drives, cables, and circuit cards.
- HGC** (Hercules<sup>®</sup> Graphics Card) A type of video display that provides medium- or high-resolution text and graphics on TTL-monochrome monitors.

**I****IC**

(Integrated Circuit) A computer chip.

**IDE**

(Integrated Drive Electronics) A type of hard disk drive with the control circuitry located inside the disk drive rather than on a drive controller card.

**interface**

A connection between the computer and a peripheral device that enables them to exchange data. *See also* parallel port and serial port.

**ISA**

(Industry Standard Architecture) An XT/AT-compatible computer or card that transfers 8 or 16 bits of data at a time.

**K****K**

(Kilobyte) 1,024 bytes. *See also* byte.

**L****LAN**

(Local Area Network) A group of computers linked together within a limited area to exchange information.

**LCD**

(Liquid Crystal Display) The type of video display used in portable computers.

**LED**

(Light-Emitting Diode) A device that glows when current is applied to it.

**LPT1 or LPT2**

The name you can assign a parallel port to specify its address. *See also* parallel port.

**M**

- M** (Megabyte) 1,048,576 bytes. *See also* byte.
- machine language** The lowest level of programming code the computer uses. Machine language code is comprised of only 1s and 0s.
- MCGA** (Multi-Color Graphics Adapter) A type of video display driver that provides medium resolution text and graphics.
- MDA** (Monochrome Display Adapter) A type of video display that provides medium-resolution text for a TTL-monochrome monitor.
- memory** The place in your computer that stores data and programs. *See also* EMS, extended memory, RAM, and ROM.
- microprocessor** The integrated circuit that processes data and controls the basic functions of the computer.
- modem** A device used to exchange information with other computers over telephone or data lines.
- Monitor program** A program built into your computer that allows you to perform a variety of tasks such as test routines.
- monochrome display** A single color video display, usually white, green, or amber, on a black background.
- mouse** A small input device that you guide on a flat surface to control the cursor movement and operation of the computer when using certain software programs.

**N****NEWBIOS**

A function of the Monitor program that allows you to reprogram the flash EPROM of a computer.

**numeric coprocessor**

An integrated circuit that works with the microprocessor to speed up mathematical calculations.

**O****operating system**

A set of programs that provide the interface between the software program and the computer.

**P****parallel communication**

Information transmitted in parallel signals, eight or more bits at a time.

**parallel port**

The connector on the back of your computer that allows the transfer of data between the computer and a parallel device, such as a parallel printer.

**partition**

To divide the storage space on a hard disk into separate areas so that the disk operating system treats them as separate disk drives.

**password**

A security feature that prevents an unauthorized user from operating your computer. *See also* EEPROM.

**peripheral**

A device connected to and controlled by the computer, such as an external disk drive or a printer.

**R****RAM**

(Random-Access Memory) A temporary storage area for data and programs. RAM differs from ROM in two ways: you can change the information stored in RAM, and the contents of RAM are erased when the power is turned off.

**real-time  
clock/calendar**

The IC in your computer that maintains the time and date.

**RGB or RGBI**

(Red, Green, Blue, Intensity) Separate video signals used to produce different colors for color monitors and different shades of one color for monochrome monitors. The addition of the intensity signal allows twice as many colors or shades to be displayed.

**ROM**

(Read-Only Memory) Computer memory that contains the basic information that tells the computer how to operate. The information stored in ROM cannot be altered and is not lost when the power is turned off.

**RS-232C port**

An industry standard serial port. *See also* serial port.

**S**

- save** To store information on a floppy disk, hard disk, magnetic tape, or some other permanent storage device.
- SCSI** (Small Computer System Interface) An industry standard interface that provides high-speed access to tape drives, hard disk drives, and other peripheral devices.
- serial communication** Information sent sequentially, one bit at a time.
- serial port** The connector on the back of your computer that allows the transfer of data between the computer and a serial device, such as a mouse, a modem, or a serial printer.
- Setup program** A program located in ROM that contains information about the hardware in the computer and how it is used.
- slushware** The small portion of RAM set aside for the temporary storage of ROM programs and routines. Slushware is used to speed up computer processing time.
- software** Computer software programs with specific functions, such as word processing, data base management, and communications.
- ST-506** An industry standard hard disk drive controller that is slower than ESDI and SCSI. *See also* ESDI and SCSI.

---

**T****tape drive**

A type of storage device using magnetic tape.

**TTL**

(Transistor-Transistor Logic) A popular family of integrated circuits used in computers. *See also* CMOS.

**U****upload**

The process of transferring information from your computer to another computer or storage device. *See also* download.

**V****VGA**

(Video Graphics Array) A type of video display that provides very-high-resolution text and graphics video modes on analog color monitors.





# Index

---

## B

- Backup battery
  - life, C-1
  - replacing, C-2
- Boot
  - from the Monitor, B-3

## C

- Circuit cards
  - installing, 4-24
- Computer
  - identifying features, 1-1
  - powering up, 1-6
  - testing, A-7, A-9
- Cover lock, 1-5

## D

- Drive bay, 4-12
- Drives
  - boot command, B-3
  - testing, A-8

## E

- Error messages, A-10
- Error recovery, A-10

## F

- Floppy disk drive
  - installing, 4-13
- Function keys, B-6

## H

- Hard disk drive
  - installing, 4-19
- Hardware upgrades
  - memory, 4-10
  - options, 4-1

## K

- Keyboard, 2-1 – 2-7
  - port, 1-3
  - testing, A-9

## M

- Memory
  - testing, A-9
  - upgrading, 4-10
- Monitor program, B-1
  - boot command, B-3
  - color bar command, B-6
  - disk read test, A-8
  - keyboard test, A-9
  - memory test, A-9
  - power-up test, A-9
  - programming commands, B-7
  - prompt, B-1
  - TEST command, A-7
  - video commands, B-4
  - video modes, B-4

## N

- Numeric coprocessor
  - installing, 4-8

**O**

Operating system  
installing, 1-7  
using, 1-7

**P**

Parallel peripheral  
port, 1-4  
Password  
changing, 3-21  
disabling, 3-21 – 3-22  
password mode, 3-19  
setting, 3-19  
Supervisor, 3-18  
User, 3-18  
Ports  
keyboard, 1-3  
parallel, 1-4  
PS/2 mouse, 1-3  
serial, 1-4  
video, 1-3  
Power cord  
connecting, 1-3  
Power cord socket, 1-3  
PS/2 mouse  
port, 1-3

**S**

Security loop, 1-5  
Serial board  
installing, 4-5  
Serial peripheral  
port, 1-4  
Service  
error messages, A-10  
user-selectable tests, A-7  
Setup program, 3-1  
boot options, 3-16  
cache selection, 3-15  
communication devices, 3-17  
disk drive options, 3-10  
entering, 3-2  
exiting, 3-23  
memory configurations, 3-8  
See Monitor program  
operating speed, 3-14  
parallel port, 3-17  
passwords, 3-18  
serial port, 3-17  
using, 3-3  
video refresh, 3-13  
SIMMs  
installing, 4-10

**V**

Video  
adjusting display, B-6  
video modes, B-4  
Video monitor  
port, 1-3

# Z-386SX/20 Owner's Manual



Groupe Bull

## Reader Response Card

We have tried to make this manual complete, accurate, concise, and easy to use. Please take a moment and send your comments to us on this tear-out, postage-paid form.

1. Was the information in this manual presented clearly?

Please explain: \_\_\_\_\_

\_\_\_\_\_

2. Was specific information you needed easy to find?

Please explain: \_\_\_\_\_

\_\_\_\_\_

3. What information that you needed was not included in the manual?

\_\_\_\_\_

\_\_\_\_\_

4. What information would you add or change to make this manual easier to use?

\_\_\_\_\_

\_\_\_\_\_

5. What information was most useful?

\_\_\_\_\_

\_\_\_\_\_

What information was least useful?

\_\_\_\_\_

\_\_\_\_\_

6. Opinion of manual:

\_\_\_\_\_

\_\_\_\_\_

\_\_\_\_\_

FOLD



NO POSTAGE  
NECESSARY  
IF MAILED  
IN THE  
UNITED STATES



**BUSINESS REPLY MAIL**

FIRST CLASS MAIL PERMIT NO. 463 ST. JOSEPH, MI

POSTAGE WILL BE PAID BY ADDRESSEE

**ZENITH DATA SYSTEMS**  
**Attn: TECH DOC**  
**P. O. BOX 1000**  
**ST. JOSEPH, MI 49085-9983**

